

EUROMOLD®/GPH® COMPACT CATALOGUE

CONNECTORS • TERMINATIONS • JOINTS • JUMPERS
CONNECTION TECHNOLOGY • TOOLS



© gjb311 / Fotolia

Technical instructions and application information

The data given were determined diligently, but do not release our customers of the duty to carry out tests themselves in order to check the suitability of the products delivered by us for the intended use. We reserve the right to modify characteristic and performance data according to the present state of technology. Processing and use of the products cannot be controlled by us and are therefore exclusively in your field of responsibility.

Our products meet the VDE standards respectively correspond to DIN pages and IEC recommendations.

Attention: Before first design in please contact manufacturer.

The products, described in this catalogue, are designed for connection of bare energy cable conductors (Class 1 & 2) with description of round solid (RE), round stranded (RM), as well as sector solid (SE), sector stranded (SM) and round stranded compacted (RMV) for conductor temperatures up to 90 °C. All conductor filling materials like tapes, yarn, powder or similar need to be completely removed before the installation. A check on basis of the actual existing conductor dimensions by the user is indispensable. This applies also for the application of Class 6 conductors or other special conductor types.

Impact wrenches have to be approved by Nexans! Depending on different conductor material or conductor type, indicated values may differ from test values acc. to IEC 61238-1. The use of fine stranded conductors has to be approved by Nexans Power Accessories Germany GmbH.

Our responsibilities are only those listed in the latest edition of "General terms and conditions for the supply of products and services of the electrical and electronics industry". We can provide a copy on request.

Our products are mainly delivered in cartons. We only use package materials able to be recycled due to the latest packing system. Collapsible cardboard boxes are not taken back. Please try to order complete standard packages.

Reprinting, even partial, only with special allowance. We reserve the right to alter or modify the characteristics described. Illustrations and drawings may only show a close reflection and are not decisive. The weights are approximate and include the carton package. This catalogue substitutes all former editions. Types or versions not part of the catalogue are available on request.

LET'S GET CONNECTED!

Nexans Power Accessories is the leading European specialized innovator, manufacturer and distributor of low, medium and high voltage accessories as well as connection technology for energy transmission and distribution networks.

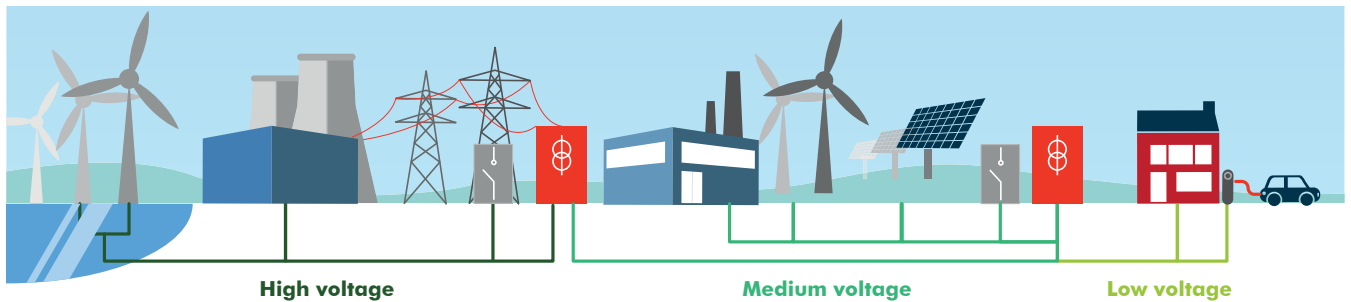

Nexans brings energy to life through an extensive range of advanced cabling and connectivity solutions. For over 120 years, innovation has been the company's hallmark, enabling Nexans to drive a safer, smarter and more efficient future together with its customers. Today, the Nexans Group is committed to facilitating energy transition by empowering its customers in four main business areas: Building & Territories (including utilities, smart grids, e-mobility), High Voltage & Projects (covering offshore wind farms, submarine interconnections, land high voltage), Telecom & Data (covering data transmission, telecom networks, hyperscale data centers, LAN) and Industry & Solutions (including renewables, transportation, Oil & Gas, automation).

Nexans Power Accessories has been a leader in pre-assembled cable accessories for more than 60 years. The company is represented in more than 40 countries worldwide.

The standard product range of **GPH**[®] compression or mechanical connectors and cable lugs is developed and produced as well as customized solutions. Nexans also manufactures ready-to-install pre-assembled cable lengths and factory tested cable bridges for industrial applications.

With the brand name **EUROMOLD**[®] we are a European market leader for medium voltage accessories. We offer the entire portfolio of separable connectors for interfaces A to F in proven EPDM technology with at least 3 mm conductive jacket. In this scope, longtime know-how and technological advance was successfully transferred into high voltage applications. We provide a complete range of cold-shrinkable and slip-on accessories up to 170 kV. For the connection of low and medium voltage cables, a series of Nexans heat-shrinkable terminations and joints up to 42 kV are available. An extensive range of additional equipment and a variety of dedicated installation training and tooling make Nexans a strong partner in the transmission and distribution of energy.

Nexans Power Accessories have set industrial standards and shaped European norms. Quality- and environmental awareness are central components of the corporate philosophy and management system. In addition to being certified according to DIN EN ISO 9001, we are also certified in the important sectors of environmental protection, energy and occupational safety.

THIS IS WHERE YOU CAN FIND US.

Wherever electricity is conducted through cables and wires. Wherever cables are connected or energy transmission and distribution is required. Wherever safety and quality have priority.

WE PROVE COMPETENCE.

Nexans products ensure operational reliability as network utilisation increases. Our references are more than 10 million connectors and cable lugs, 1.1 million pre-manufactured accessories and around 33,000 jumpers per year.

WE TAKE RESPONSIBILITY.

Nexans Power Accessories currently produces accessories from 1 kV to 500 kV. As we are the Centre of Competence for cable accessories, we have taken on responsibility for R&D in the Nexans Group for cable connection technology.

STANDARDS ARE IMPORTANT TO US.

Our accessories meet the requirements of the following standards: EN 61442, HD 629.1, HD 629.2, EN 50180, EN 50181, IEC 60137, IEEE 386 & 404, IEC 61238-1, VDE 0220 T100, etc.

WE ARE CERTIFIED.

DIN EN ISO 9001:2015,
DIN EN ISO 14001:2015,
DIN EN ISO 50001,
OHRIS



POWER ACCESSORIES FOR ENERGY CABLES

A compact selection of our accessories

up to 42 kV, 1250 A

Power accessories for energy cables	Page
EPDM in connection technology	4
Examples of application	5

EUROMOLD® Separable connectors up to 42 kV

200LR/G - Elbow connector	8
200SR/G - Straight connector	10
PITO-E - Termination	12
Overview Interface A	13
400LR/G - Elbow connector	14
Overview Interface B	16
Installation overview compact tee connector 480TB/G	17
480TB/G - Compact tee connector	18
800PB/G - Coupling connector	20
484TB/G - Compact tee connector	22
804PB/G - Coupling connector	24
489TB/G - Compact tee connector	26
809PB/G - Coupling connector	28
800SA - Surge arrester	30
480BE/G - Asymmetrical bushing extender	32
400TR/800TR/800TR-A - Test rod for cable testing	33
Possible arrangements Interface C	34
Overview Interface C	35

Slip-on terminations up to 42 kV

AIS - Indoor slip-on termination	38
AIP - Indoor slip-on termination	40
AIN - Indoor slip-on termination	42
AFS - Outdoor slip-on termination	45
AFN - Outdoor slip-on termination	47

POWER ACCESSORIES FOR ENERGY CABLES

A compact selection of our accessories
up to 42 kV, 1250 A

Page

Ready-to-install, pre-assembled cables up to 42 kV

52

Straight joints • transition joints up to 42 kV

GTS1 - Single-core straight joint, heat-shrink technology	56
CSJ - Single-core straight joint, cold-shrink technology	58
24CSJA-S - Compact single-core straight joint, cold-shrink technology	60
GTM3.1 - Three-core transition joint, heat-shrink technology	62
SVMS/SVMS-P - In-line joint including mechanical connectors, heat-shrink technology	64

GPH® Connection technology up to 52 kV

Mechanical Connectors GPH® D-Series	68
Mechanical Cable Lugs GPH® D-Series	70
Mechanical Connectors GPH® M-Series	72
Mechanical Cable Lugs GPH® C-Series	74
Compression cable lugs, Cu	76
Compression cable lugs, Cu, acc. to DIN 46235	78
Compression cable lugs, Al, acc. to DIN 46235	80

Tools

Cable preparation tools	84
Torque amplifier DMV65 with tool case	87
Torque amplifier DMV65, isolated, with tool case	88
Torque amplifier iDMV65 with integrated drive and tool case	89

Catalogue selection

90

Cable data sheet / Inquiry form

91

POWER ACCESSORIES FOR ENERGY CABLES

EPDM (ethylene propylene diene monomer)
in connection technology

Why is EPDM used for slip-on accessories all over the world?

EPDM has been used successfully as an insulating and control material for several million of cable connectors worldwide for more than 55 years. Compared with the frequency of which other materials, such as silicone, are used for separable connectors, EPDM reaches more than 95%. Separable connectors are used at voltage levels from 3.6/6 kV to 26/45 kV (52 kV) in the medium voltage range for all possible applications, such as switch gears, motors, transformers, trains etc. in both indoor and outdoor facilities. Outer cone solutions have also been used for connecting high-voltage installations up to 220 kV for roughly 15 years.

The following advantages set EPDM in the pole position as the insulating and control material for separable connectors.

- Thick-walled conductive EPDM jacket with high mechanical load capacity. A metal housing is not necessary.
- The function of the earth connection to the conductive EPDM jacket of the connector is always ensured so that damage

to the material caused by electric discharges between the surface of the connector / air and the surface of the connector / metal (earthed system parts) is impossible. The EPDM material does not release any volatile substances accumulating on the surface having negative effects on the conductivity of the shielding after a longer period of time.

- Connectors made of EPDM meet all international standard testings to the utmost satisfaction, including the reignition test for detecting a fault, even at low operating voltages, e.g. 6/10 kV.
- Problems when removing connectors (if systems are replaced or moved, even after decades) caused by the material sticking to the bushing of the system are impossible. The silicone based lubricant that is used when assembling the connector, does not diffuse into the material, but remains in the gap between connector and bushing. De-energised connectors can be removed at any time, if required.
- Due to the dimensionally

stable EPDM material, it is not possible to mount the pin contact in a wrong place, which often happens using "softer" materials, even with a built-in anti-twist safeguard in the cable lug area.

- Due to the hard, smooth surface of the EPDM material, damage caused by animals is not known. In this respect, operational reliability in endangered areas is ensured.
- Thanks to innovative technological advance of the EPDM material and the connector designs, multirange connectors are available today that are characterised by their ease of installation.

From an objective point of view, the EPDM material has clear advantages in connector technology over all other materials, just as silicone for slip-on terminations.

POWER ACCESSORIES FOR ENERGY CABLES

Examples of application



AIS20 with mechanical cable lug



PITO-E on transformer with bushings



Transformer connection with 158LR



Transformer connection with 200LR

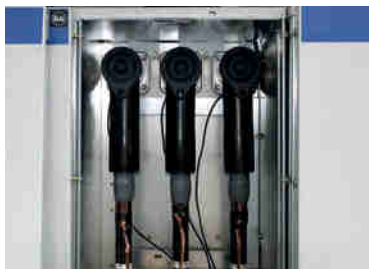

SF-6 system connection with 480TB



SF-6 system connection with 480TB+800SA



TS-24CSJ hybrid transition joint



AFN10 as a transformer connection



AIP20 as a transformer connection



AFN20 for smaller and larger cross-sections



GTS1 heat-shrinkable straight joint



24CSJA-S cold-shrinkable straight joint

15-01-2019





EUROMOLD®
SEPARABLE CONNECTORS
up to 42 kV

200LR/G EUROMOLD® Elbow connector

Interface A
up to 24 kV, 250 A

Application

Suitable for installation on polymeric insulated medium voltage cables with extruded easy strip conductive screen or bonded extruded conductive screen. For use with other cable types please contact our sales representative.

Technical characteristics

- The thick conductive EPDM jacket provides a total safe to touch screen to ensure safety.
- New, compact design.
- Self-locking bolted contact with anti-twist system.
- Each separable connector is tested for AC withstand and partial discharge prior to leaving the factory.

$U_0 / U (U_m)$
6/10 (12) kV
6.35/11 (12) kV
8.7/15 (17.5) kV
12/20 (24) kV
12.7/22 (24) kV

Design

1. Conductive EPDM insert with integrated anti-twist and locking system
2. Conductive EPDM jacket
3. Insulating EPDM layer between insert and jacket
4. Type A interface as described by CENELEC EN 50180 and 50181
5. Bolted conductor contact
6. Earthing lead
7. Cable reducer

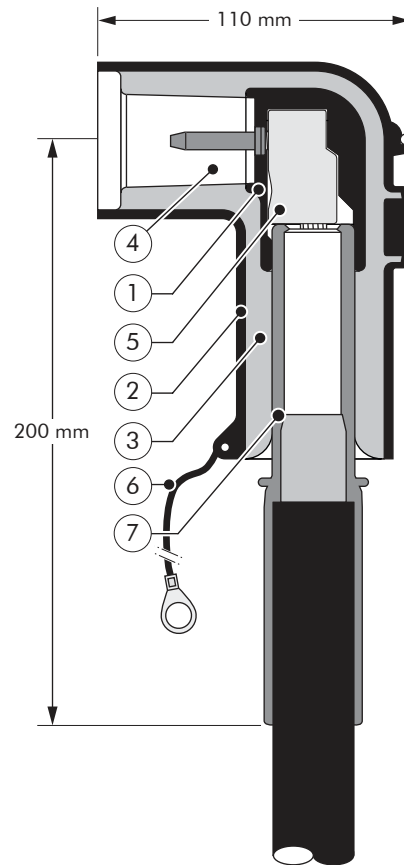

Specifications and standards

The elbow connector 200LR/G meets the requirements of CENELEC HD 629.1.

Separable connector type	Nominal voltage U_0 / U (kV)	Current I_n (A)	Conductor cross-section (mm ²)	
			min.	max.
200LR/G	6/10	250	25	95
K200LR/G	12/20	250	35	95

Kit contents

The complete (K)200LR/G elbow connector kit comprises 3 x the following components:

The kit also comprises:
 + installation instructions
 + silicone grease
 + wipers
 + screen wire cable lugs

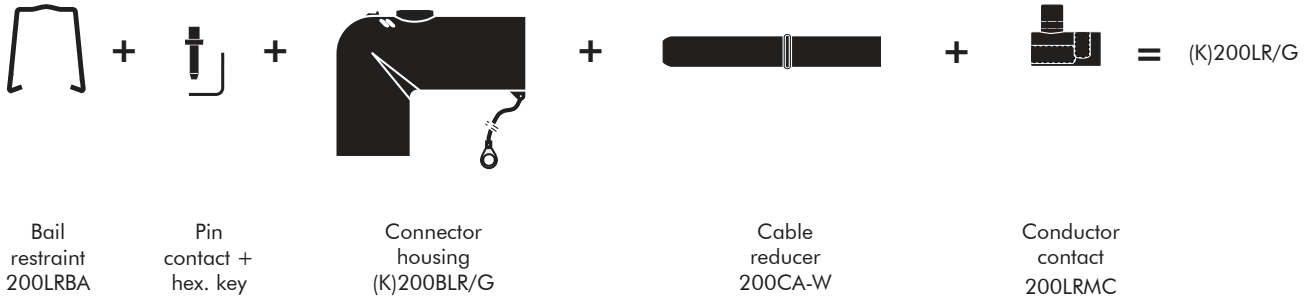

Ordering instructions

Indicate the part number when ordering (see table).

Order example:

1 elbow connector kit for 12/20 kV, for 35-95 mm² with mechanical conductor contact.

Order according to the table:
 1 kit – K200LR/G with part number 501471.

Note: The assignment only applies to XLPE-insulated cables (dimensions according to DIN VDE 0276-620) with extruded conductive screen and stranded conductors. For use with other cable designs contact our sales representative.

Cross-section (mm ²)	Dia. over core insulation (mm)		Ordering part number for (K)200LR/G
	min.	max.	with mechanical conductor contact
Nominal voltage U₀/U 6/10 kV			
25	13.0	21.0	501470
35			
50			
70			
95			
Nominal voltage U₀/U 12/20 kV (K)			
35	17.5	25.0	501471
50			
70			
95			

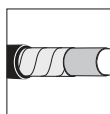

For use with copper tape screened cables.
 Order : KIT MT.



For use with other cable types please contact our representative.



For outdoor applications.

200SR/G EUROMOLD® Straight connector

Interface A
up to 24 kV, 250 A

Application

Suitable for installation on polymeric insulated medium voltage cables with extruded easy strip conductive screen or bonded extruded conductive screen. For use with other cable types please contact our sales representative.

Technical characteristics

- The thick conductive EPDM jacket provides a total safe to touch screen to ensure safety.
- New, compact design.
- Self-locking bolted contact with anti-twist system.
- Each separable connector is tested for AC withstand and partial discharge prior to leaving the factory.

$U_0 / U (U_m)$
6/10 (12) kV
6.35/11 (12) kV
8.7/15 (17.5) kV
12/20 (24) kV
12.7/22 (24) kV

Design

1. Conductive EPDM insert with integrated anti-twist and locking system
2. Conductive EPDM jacket
3. Insulating EPDM layer between insert and jacket
4. Type A interface as described by CENELEC EN 50180 and 50181
5. Bolted conductor contact
6. Earthing lead
7. Cable reducer

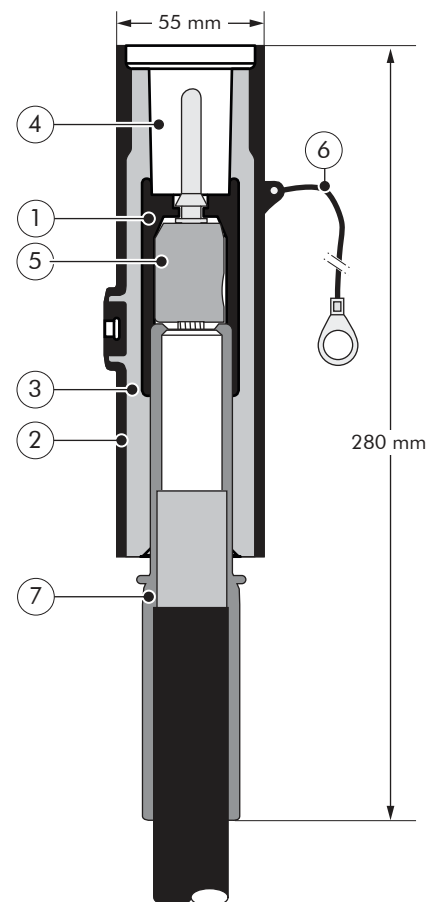

Specifications and standards

The straight connector 200SR/G meets the requirements of CENELEC HD 629.1.

Separable connector type	Nominal voltage U_0 / U (kV)	Current I_n (A)	Conductor cross-section (mm ²)	
			min.	max.
200SR/G	6/10	250	25	95
K200SR/G	12/20	250	35	95

Kit contents

The complete (K)200SR/G straight connector kit comprises 3 x the following components:

The kit also comprises:
 + installation instructions
 + silicone grease
 + wipers
 + screen wire cable lugs

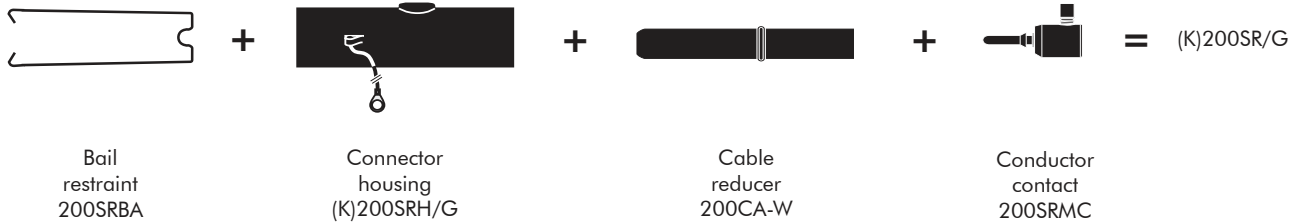

Ordering instructions

Indicate the part number when ordering (see table).

Order example:

1 straight connector kit for 12/20 kV, for 35-95 mm² with mechanical conductor contact.

Order according to the table:
 1 kit – K200SR/G with part number 501473.

Note: The assignment only applies to XLPE-insulated cables (dimensions according to DIN VDE 0276-620) with extruded conductive screen and stranded conductors. For use with other cable designs contact our sales representative.

Cross-section (mm ²)	Dia. over core insulation (mm)		Ordering part number for (K)200SR/G
	min.	max.	with mechanical conductor contact
Nominal voltage U₀/U 6/10 kV			
25	13.0	21.0	501472
35			
50			
70			
95			
Nominal voltage U₀/U 12/20 kV (K)			
35	17.5	25.0	501473
50			
70			
95			

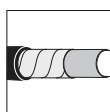

For use with copper tape screened cables.
 Order : KIT MT.



For use with other cable types please contact our representative.



For outdoor applications.

PITO-E EUROMOLD® Termination

Interface A
up to 24 kV, 250 A

Application

Separable termination designed to connect overhead lines or bus bars to equipment. Is suitable for indoor and outdoor use for medium polluted atmosphere.

Technical characteristics

Each plug-in termination is tested for AC withstand prior to leaving the factory.

$U_0 / U (U_m)$
6/10 (12) kV
6.35/11 (12) kV
8.7/15 (17.5) kV
12/20 (24) kV
12.7/22 (24) kV

Design

The plug-in termination is a moulded epoxy insulated part. It meets the type A - 250 A interface as described by CENELEC EN 50180 and 50181.

Specifications and standards

The PITO-E can be used with equipment interface parts type A that correspond to the international standard for outer cone systems according to CENELEC EN 50180 and EN 50181.

Ordering instructions

Plug-in termination PITO-E up to 24 kV.

Dedicated fastening material:

- + 2 polyamide bolts,
- + 2 polyamide nuts,
- + 2 metal pins.

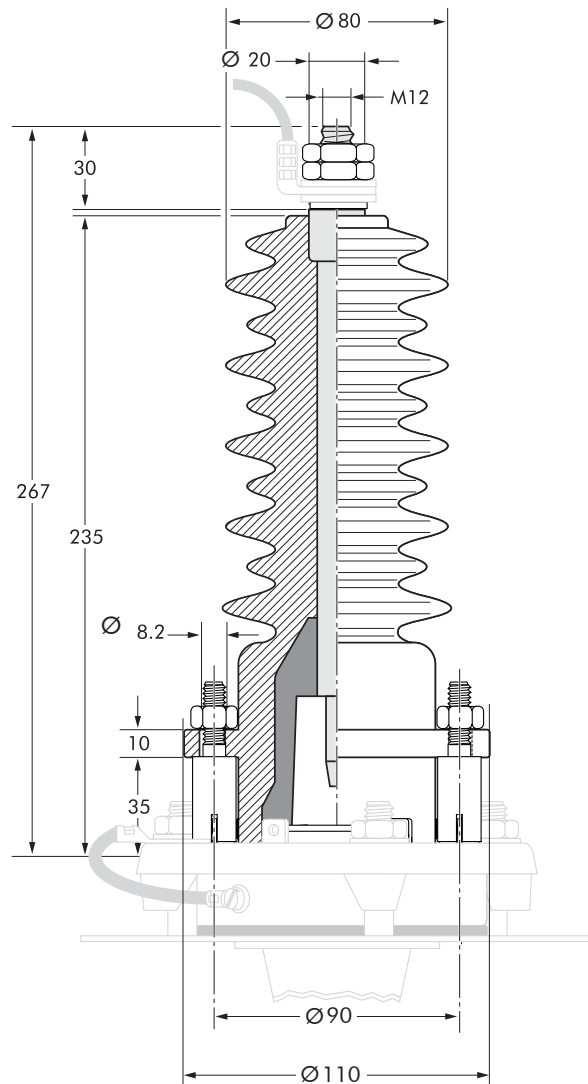

Plug-in termination type	Nominal voltage U_0 / U (kV)	Current I_n (A)	Creepage distance (mm)	Part number
PITO-E	12.7/22	250	510	70275

CONNECTING POSSIBILITIES EUROMOLD® PIN-CONNECTOR SYSTEM

Interface A

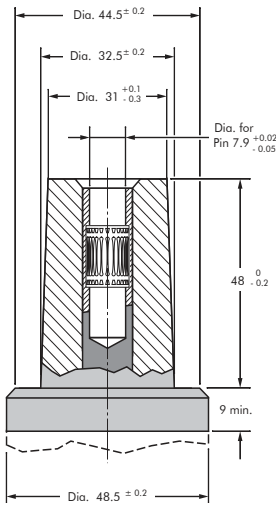

Interface A
250 A outer cone acc. to
CENELEC EN 50180 and
EN 50181

U₀ / U (U_m)
6/10 (12) kV
6.35/11 (12) kV
8.7/15 (17.5) kV
12/20 (24) kV
12.7/22 (24) kV

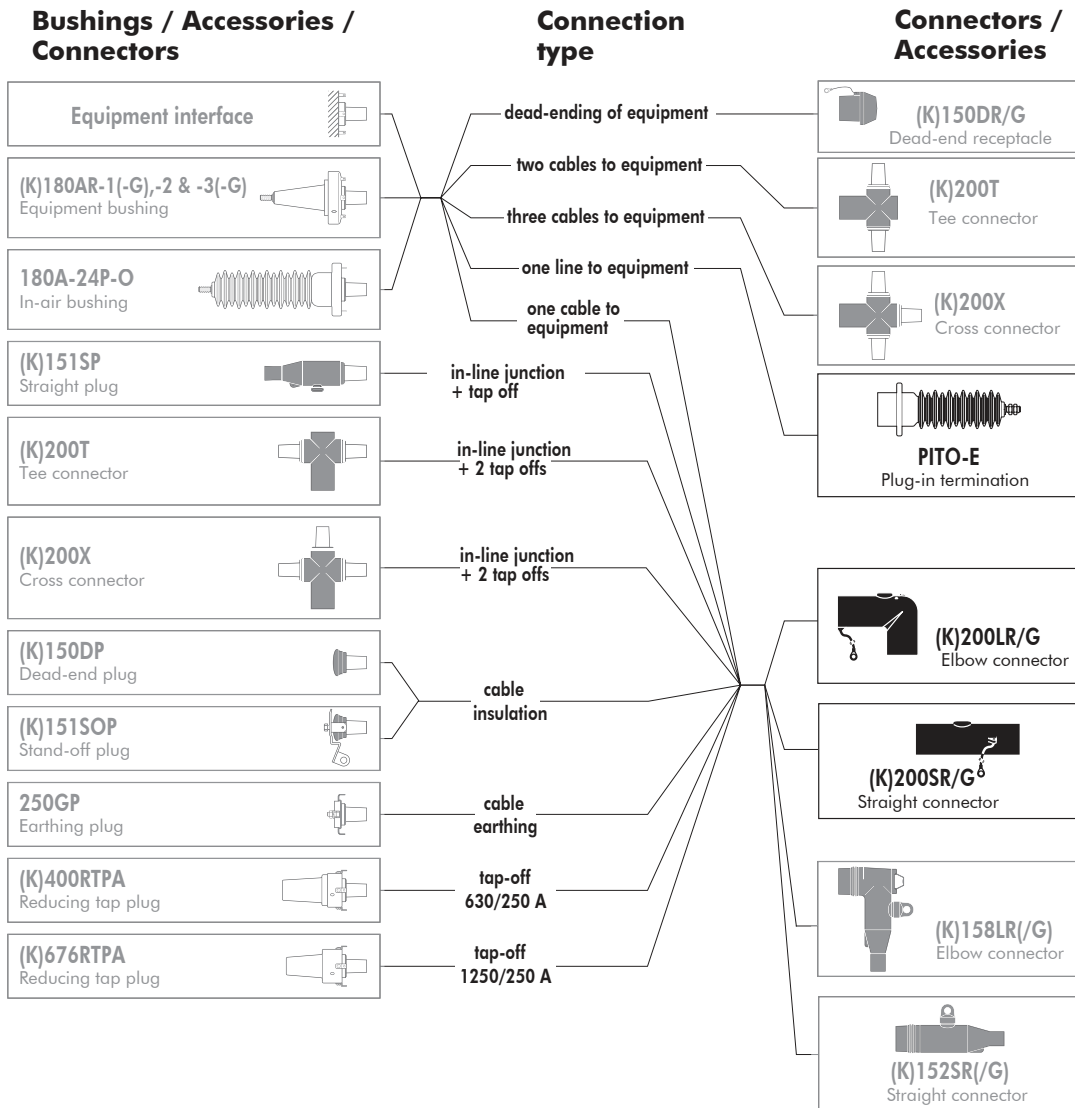

Products displayed in **grey** are generally available, but not part of this catalogue.

400LR/G EUROMOLD® Elbow connector

Interface A
up to 36 kV, 400 A

Application

Separable elbow connector (plug-in type) designed to connect polymeric insulated cable to equipment (transformers, switchgear, motors etc.). For use with other cable types please contact our sales representative.

Technical characteristics

- The thick conductive EPDM jacket provides a total safe to touch screen which ensures safety for personnel.
- Each separable connector is tested for AC withstand and partial discharge prior to leaving the factory.

$U_0 / U (U_m)$
6/10 (12) kV
6.35/11 (12) kV
8.7/15 (17.5) kV
12/20 (24) kV
12.7/22 (24) kV
18/30 (36) kV
19/33 (36) kV

Design

1. Conductive EPDM insert
2. Conductive EPDM jacket
3. Insulating EPDM layer moulded between the insert and the jacket
4. Type B - 400 A interface as described by CENELEC EN 50180 and 50181
5. Bolted or crimp conductor contact
6. Cable reducer
7. Earthing lead

The screen break design enables cable outer sheath testing without removing or dismantling the connector.

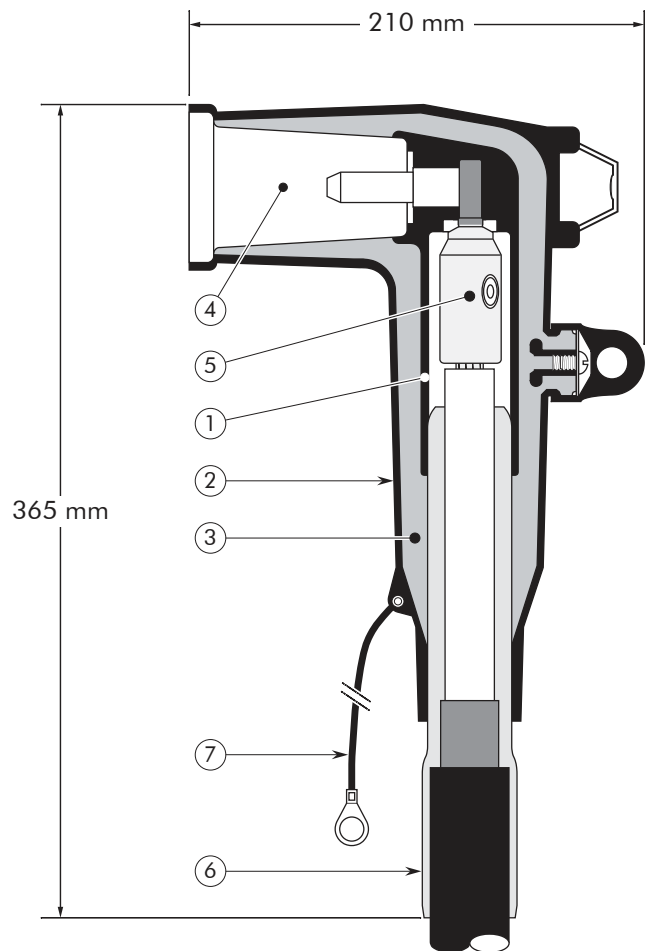

Specifications and standards

The separable connector 400LR/G meets the requirements of CENELEC HD 629.1.

Separable connector type	Nominal voltage U_0/U (kV)	Current I_n (A)	Conductor cross-section (mm ²)	
			min.	max.
400LR/G	6/10	400	25	300
K400LR/G	12/20	400	35	300
M400LR/G	18/30	400	50	240

Kit contents

The complete (K)(M)400LR/G elbow connector kit comprises the following components:

The kit also comprises:
 + installation instructions
 + silicone grease
 + wipers
 + screen wire cable lugs

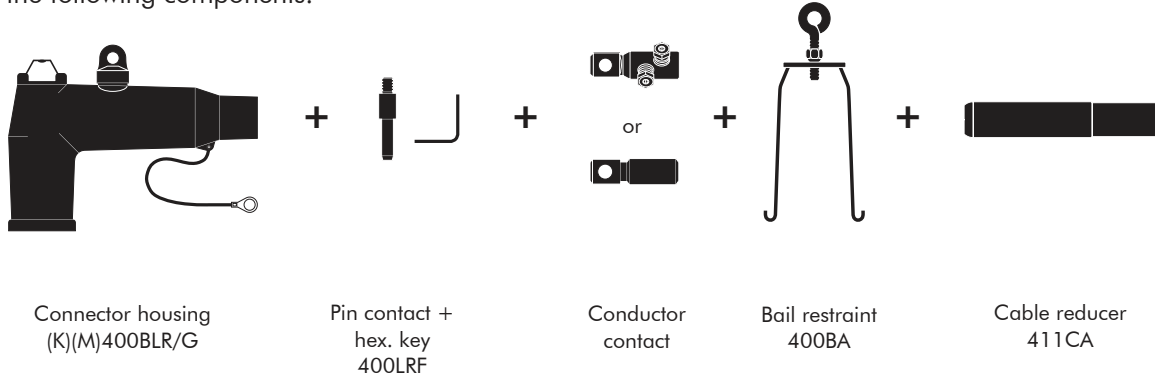

Ordering instructions

Indicate the part number when ordering (see table).

Order example:

a) 1 elbow connector kit for 12/20 kV, for 120-185 mm² with mechanical conductor connector.

Order according to the table: 1 kit – K400LR/G with part number 52262.

b) 1 elbow connector kit for 12/20 kV, for 150 mm² with compression connector for Al conductors.

Order according to the table: 1 kit – K400LR/G with part number 48365.

Note: The classification does only apply for polymeric insulated XLPE cables (dimensions acc. to DIN VDE 0276 620) with extruded conductive screen and stranded conductors. Please contact our sales representative, when using other cable types.

Cross-section (mm ²)	Dia. over core insulation (mm)		Ordering part number (K)(M)400LR/G			
	min.	max.	with mechanical connector		with compression connector	
			Al-rm(v)	Cu-rm(v)		
Nominal voltage U₀/U 6/10 kV						
25	13.0	15.2	400LR/G-11		52994	52998
35	14.1	16.3	58164		52995	43690
50	15.3	17.5			52996	43412
70	17.0	19.2		400LR/G-15	52997	52247
95	17.9	20.8		52991	52248	52249
120	19.4	22.8			52250	52251
150	20.9	24.3			52252	52253
185	22.5	25.9		400LR/G-19	52254	52255
240	25.0	28.4			52256	52257
300	27.7	30.4			52993	52258
Nominal voltage U₀/U 12/20 kV (K)						
35	18.3	20.5	K400LR/G-15		52265	49447
50	19.5	21.7	52260		52266	51781
70	21.2	23.4		K400LR/G-19	52267	51275
95	22.8	25.0		52261	52034	51819
120	23.6	27.0			49686	51248
150	25.1	28.5			48365	48502
185	26.7	30.1		K400LR/G-22	52262	52268
240	29.2	32.6			49687	52270
300	31.2	34.6			52263	52271
Nominal voltage U₀/U 18/30 kV (M)						
50	23.8	26.7	M400LR/G-22		49589	44215
70	25.5	28.4	52273		51824	51093
95	27.1	30.0			48086	49645
120	28.6	32.0			51182	51377
150	30.1	33.5			53073	49721
185	31.7	35.1		M400LR/G-27	52277	52278
240	34.2	37.6		52274	43415	52275

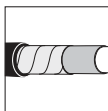

For use with copper tape screened cables.
Order: Kit MT..



For use with other cable types please contact our representative.



For outdoor applications.
Order: +MWS.

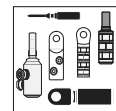

All accessories available with mechanical or compression conductor connector.

CONNECTING POSSIBILITIES EUROMOLD® PIN-CONNECTOR SYSTEM

Interface B

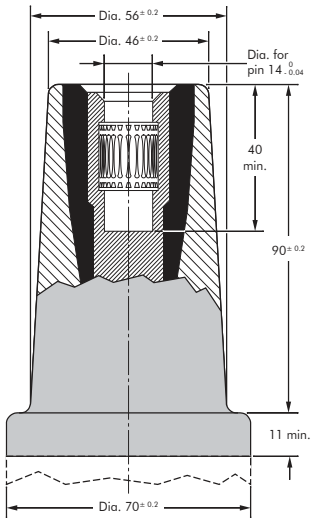

Interface B
400 A outer cone acc. to
CENELEC EN 50180 and
EN 50181

$U_0 / U (U_m)$
6/10 (12) kV
6.35/11 (12) kV
8.7/15 (17.5) kV
12/20 (24) kV
12.7/22 (24) kV
18/30 (36) kV
19/33 (36) kV

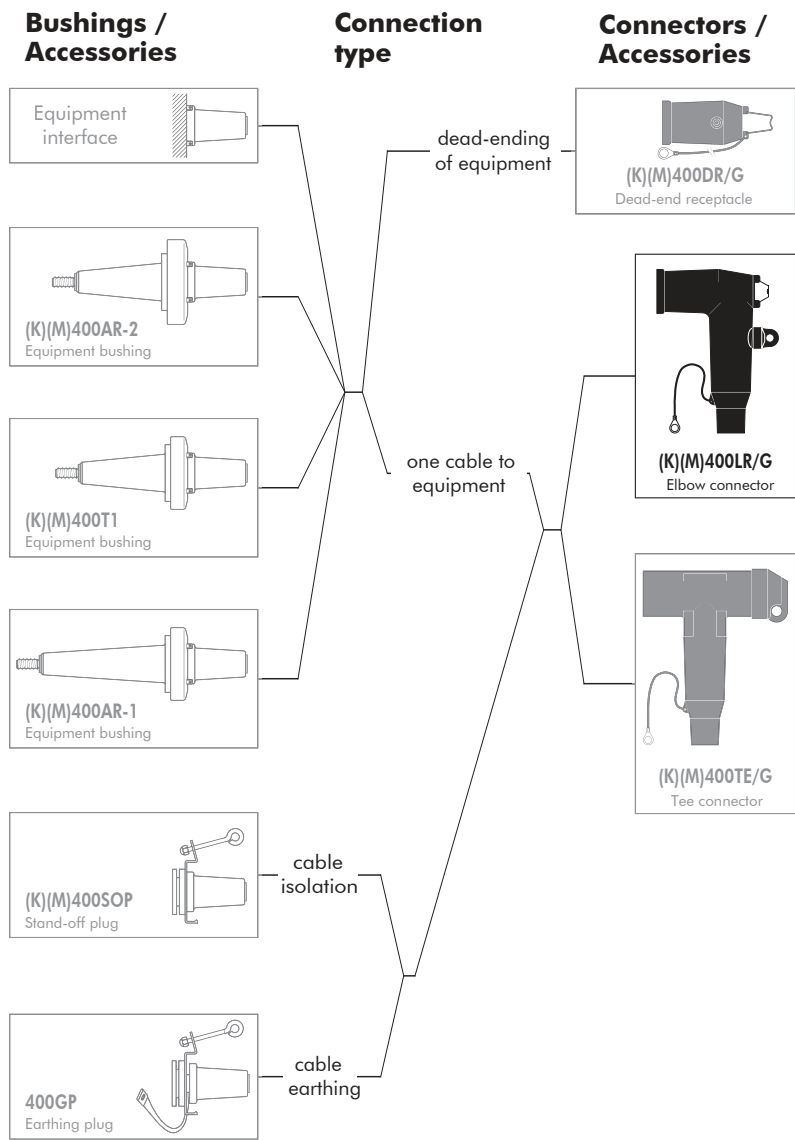

Products displayed in **grey** are generally available, but not part of this catalogue.

INSTALLATION OVERVIEW

Interface C

480TB/G

EUROMOLD® Compact tee connector for application in multiple voltage levels

Connector installation on the cable

The locking device on the mechanical conductor connector TMBC prevents the connector housing from sliding back.

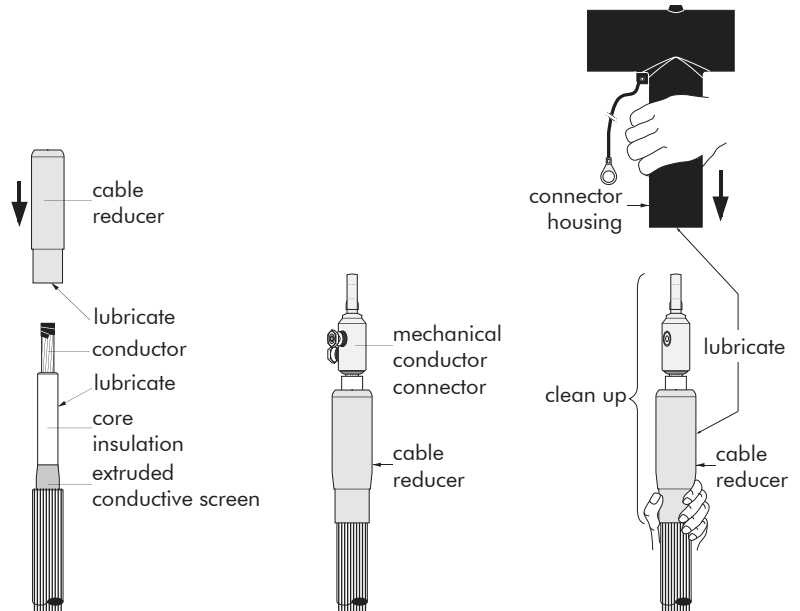
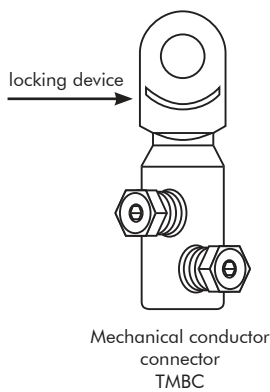

Connector installation on the bushing

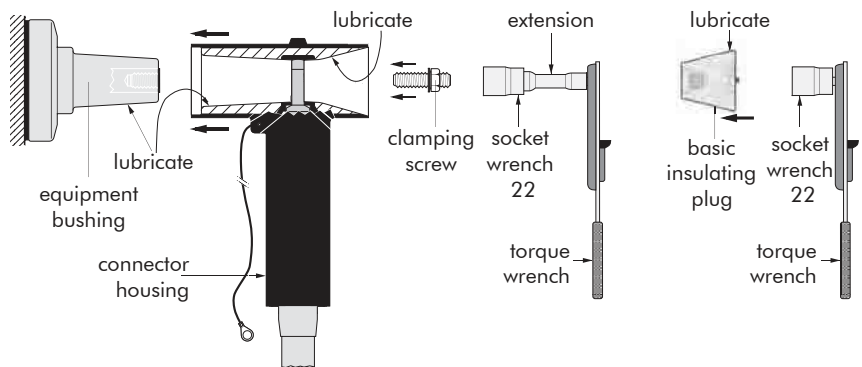

Earthing and cable fixing

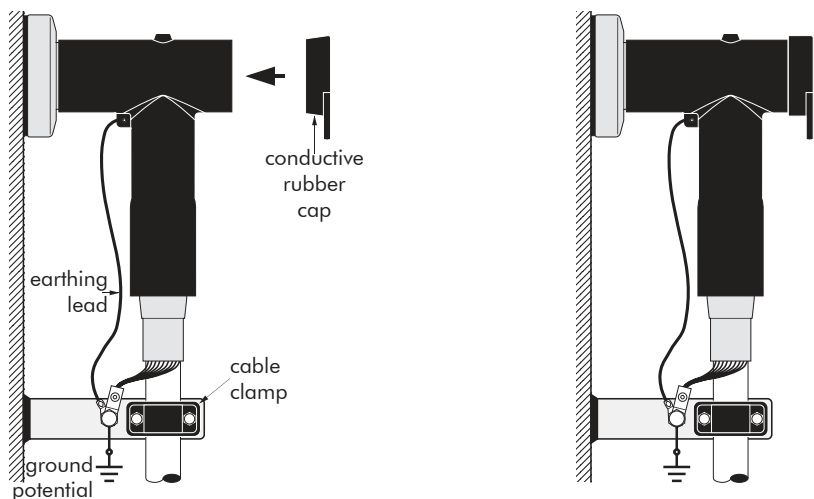

15-01-2019

480TB/G EUROMOLD® Compact tee connector for multiple voltage levels

Interface C

up to 42 kV, 630 A/1250 A¹⁾

Application

Suitable for installation on polymeric insulated medium voltage cables with extruded easy strip conductive screen or bonded extruded conductive screen. For use with other cable types please contact our sales representative.

Technical characteristics

- The thick conductive EPDM jacket provides a total safe to touch screen to ensure safety.
- Metal housing available on request.
- For use with test rod 800TR/800TR-A.
- Each separable connector is tested for AC withstand and partial discharge prior to leaving the factory.

$U_0 / U (U_m)$
6/10 (12) kV
6.35/11 (12) kV
8.7/15 (17.5) kV
12/20 (24) kV
12.7/22 (24) kV
18/30 (36) kV
19/33 (36) kV
20.8/36 (42) kV

Design

1. Conductive EPDM insert
2. Conductive EPDM jacket
3. Insulating EPDM layer
4. Type C1 + C2 interface as described by CENELEC EN 50180 and 50181
5. Bolted or crimp conductor contact
6. Basic insulating plug (with voltage detection point, standard from 30 kV)
7. Cable reducer
8. Conductive rubber cap
9. Clamping screw 430 TCS (optional M16 stud with spring washer and nut)
10. Earth lead

The screen break design enables cable outer sheath testing without removing or dismantling the connector.

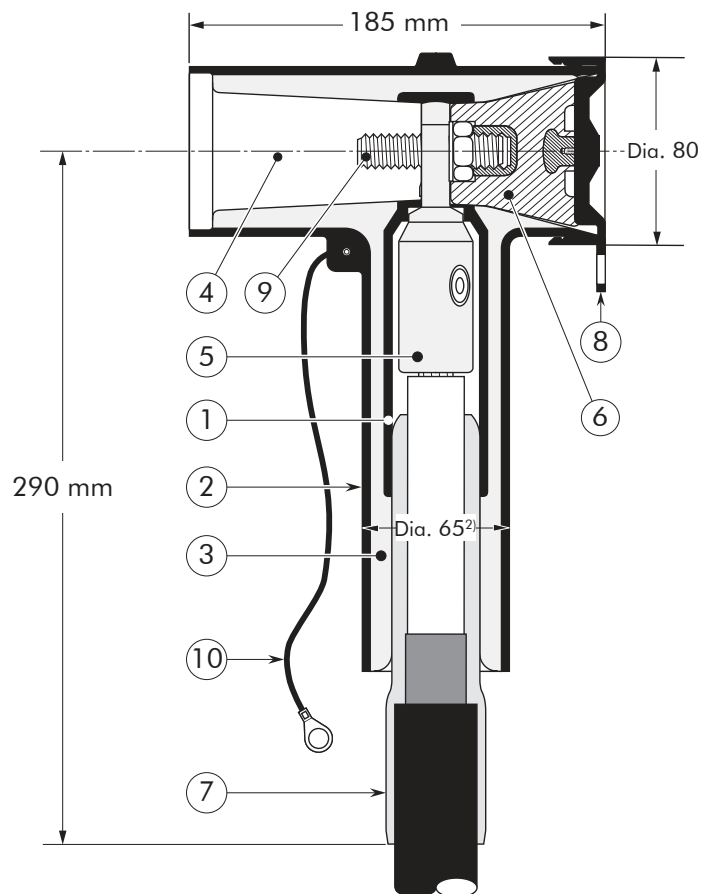

²⁾The indicated diameter is a die dimension. Depending on the conductor cross-section used, a deviation of up to +5 mm is possible.

Specifications and standards

The 480TB/G separable connector meets the requirements of CENELEC HD 629.1. ATEX version can be delivered on request.

Separable connector type	Nominal voltage U_0 / U (kV)	Current I_n (A)	Conductor cross-section (mm ²)	
			min.	max.
480TB/G	6/10	630/1250 ¹⁾	25	300
K480TB/G	12/20	630/1250 ¹⁾	35	300
M480TB/G	18/30	630/1250 ¹⁾	50	300
P480TB/G	20.8/36	630/1250 ¹⁾	50	240

¹⁾When installed on appropriate equipment bushing.

Kit contents

The complete (K)(M)(P)480TB/G tee connector kit comprises 3 x the following components:

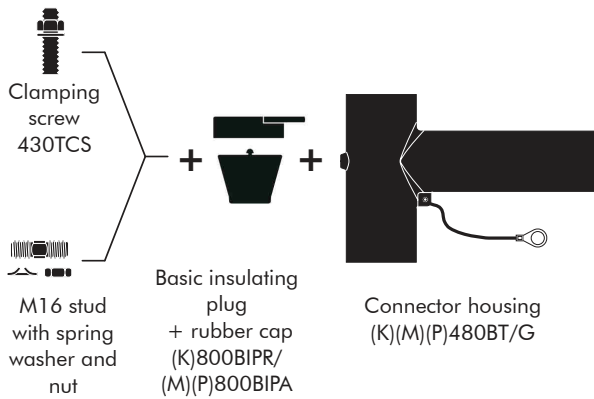

The kit also comprises:
 + installation instructions
 + silicone grease
 + wipers
 + screen wire cable lugs

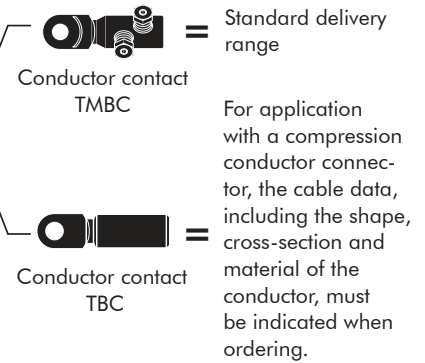

Ordering instructions

Indicate the part number for multirange application when ordering (see table).

Order example:

1 compact tee connector kit for 12/20 kV, for 95-300 mm² with mechanical conductor connector and clamping screw 430 TCS. Order according to the table: 1 kit – K480TB/G with part number 501133.

Note: The classification does only apply for polymeric insulated XLPE cables (dimensions acc. to DIN VDE 0276 620) with extruded conductive screen and stranded conductors.

³⁾ Since the dimensions for cables at voltage level 20.8/36 (42) kV are not yet standardised, the conductor cross-sections and their assignment of diameters over core insulation given in the table are to be considered approximate values. When ordering accessories, we would like to ask you to indicate the checked diameters over core insulation.

Cross-section (mm ²)	Dia. over core insulation (mm)		Multirange assignment Ordering part number for (K)(M)(P)480TB/G with mechanical connector TMBC	
	min.	max.	with clamping screw 430TCS / with M16 stud	
Nominal voltage U₀/U 6/10 kV				
25	13.0	15.2	501125/ 501126	
35	14.1	16.3		
50	15.3	17.5		
70	17.0	19.2		
95	17.9	20.8		501127/ 501128
120	19.4	22.8		
150	20.9	24.3		
185	22.5	25.9		
240	25.0	28.4		501129/ 501130
300	27.7	30.4		
Nominal voltage U₀/U 12/20 kV (K)				
35	18.3	20.5	501131/ 501132	
50	19.5	21.7		
70	21.2	23.4		
95	22.8	25.0		
120	23.6	27.0		501133/ 501134
150	25.1	28.5		
185	26.7	30.1		
240	29.2	32.6		501135/ 501136
300	31.2	34.6		
Nominal voltage U₀/U 18/30 kV (M)				
50	23.8	26.7	501137/ 501138	
70	25.5	28.4		
95	27.1	30.0		
120	28.6	32.0		
150	30.1	33.5		501139/ 501140
185	31.7	35.1		
240	34.2	37.6		501141/ 501142
300	36.9	39.6		
Nominal voltage U₀/U 20.8/36 kV³⁾ (P)				
50	23.8	26.7	501143/ 501144	
70	25.5	28.4		
95	27.1	30.0		
120	28.6	32.0		
150	30.1	33.5		501145/ 501146
185	31.7	35.1		
240	34.2	37.6		

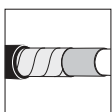

For use with copper tape screened cables. Order: Kit MT.



For use with other cable types please contact our representative.



For outdoor applications.



If an ATEX certification for connectors up to 12 kV is required, contact our sales representative before ordering.



All accessories available with mechanical or compression conductor connector.



When installed on appropriate equipment bushing: 1250 A continuously.

800PB/G EUROMOLD® Coupling connector for 480TB/G, 484TB/G and 489TB/G

Interface C

up to 42 kV, 630 A/1250 A¹⁾

Application

Separable coupling connector 800PB/G for dual cable arrangement. It has been designed to be used with 480TB/G, 484TB/G or 489TB/G separable tee connector. The cable arrangement might be extended by multiple coupling connectors.

Technical characteristics

- A thick conductive EPDM jacket provides a total safe to touch screen.
- For use with test rod 800TR/800TR-A.
- Each separable connector is tested for AC withstand and partial discharge prior to leaving the factory.

$U_0 / U (U_m)$
6/10 (12) kV
6.35/11 (12) kV
8.7/15 (17.5) kV
12/20 (24) kV
12.7/22 (24) kV
18/30 (36) kV
19/33 (36) kV
20.8/36 (42) kV

Design

1. Interface designed to fit 480TB/G, 484TB/G or 489TB/G tee connector
 2. Bus for 800PB/G
 3. Bolted or crimp conductor contact
 4. Conductive EPDM insert
 5. Conductive EPDM jacket
 6. Insulating EPDM layer moulded between the insert and the jacket
 7. Cable reducer
 8. Conductive EPDM cap
 9. Basic insulating plug (with voltage detection point, standard from 30 kV)
 10. Earth lead
- The screen break design enables cable outer sheath testing without removing or dismantling the connector.

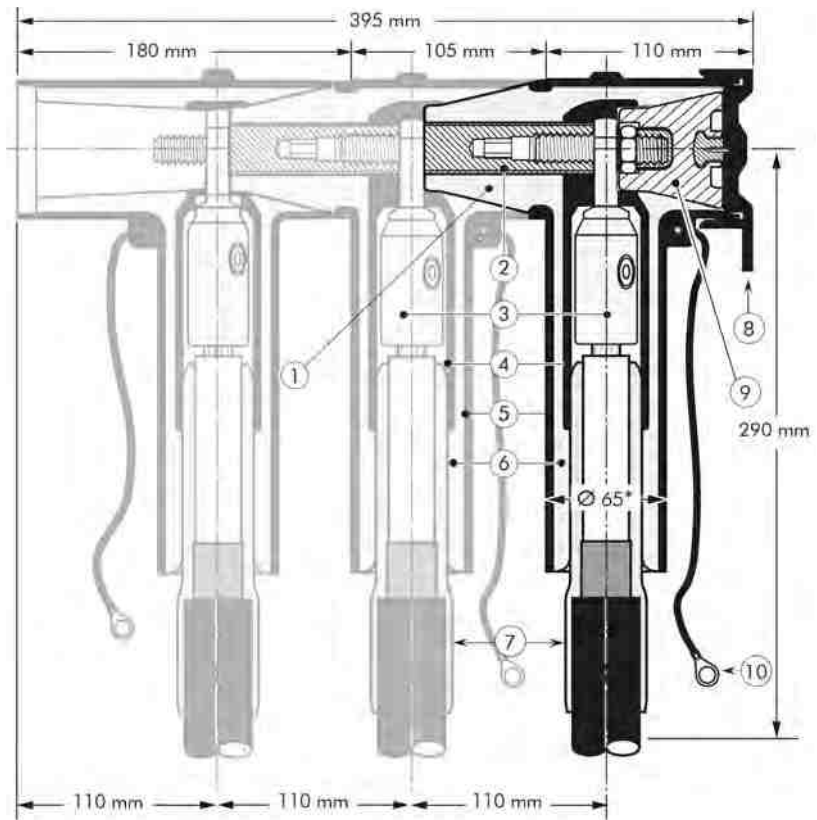

(K)(M)(P) 480TB/G Compact tee connector (K)(M)(P) 800PB/G Coupling connector (K)(M)(P) 800PB/G Coupling connector

²⁾ The indicated diameter is a die dimension. Depending on the conductor cross-section used, a deviation of up to +5 mm is possible.

Specifications and standards

The 800PB/G coupling connector meets the requirements of CENELEC HD 629.1. ATEX version can be delivered on request.

Separable connector type	Nominal voltage U_0 / U (kV)	Current I_n (A)	Conductor cross-section (mm ²)	
			min.	max.
800PB/G	6/10	630/1250 ¹⁾	25	300
K800PB/G	12/20	630/1250 ¹⁾	35	300
M800PB/G	18/30	630/1250 ¹⁾	50	300
P800PB/G	20.8/36	630/1250 ¹⁾	50	240

¹⁾ When installed on appropriate equipment bushing.

Kit contents

The complete (K)(M)(P)800PB/G coupling connector kit comprises 3 x the following components:

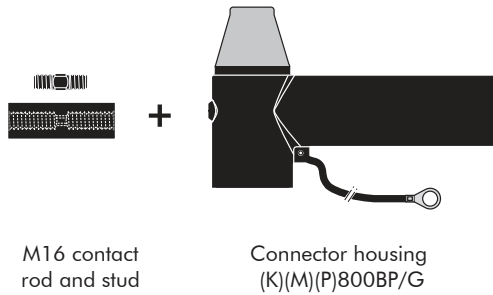

M16 contact rod and stud

Connector housing (K)(M)(P)800BP/G

Cable reducer 430CA

The kit also comprises:
 + installation instructions
 + silicone grease
 + wipers
 + screen wire cable lugs



Standard delivery range
 For application with a compression conductor connector, the cable data, including the shape, cross-section and material of the conductor, must be indicated when ordering.

Ordering instructions

Indicate the part number for multirange application when ordering (see table).

Order example:

1 coupling connector kit for 12/20 kV, for 95-300 mm² with mechanical conductor connector.
 Order according to the table: K800PB/G with part number 501151.

Note: The classification does only apply for polymeric insulated XLPE cables (dimensions acc. to DIN VDE 0276 620) with extruded conductive screen and stranded conductors.
³⁾ Since the dimensions for cables at voltage level 20.8/36 (42) kV are not yet standardised, the conductor cross-sections and their assignment of diameters over core insulation given in the table are to be considered approximate values.
 When ordering accessories, we would like to ask you to indicate the checked diameters over core insulation.

Cross-section (mm ²)	Dia. over core insulation (mm)		Multirange assignment Ordering part number for (K)(M)(P)800PB/G					
	min.	max.	with mechanical connector TMBC					
Nominal voltage U₀/U 6/10 kV								
25	13.0	15.2	501147	501148	501149			
35	14.1	16.3						
50	15.3	17.5						
70	17.0	19.2						
95	17.9	20.8						
120	19.4	22.8	501150	501151	501152			
150	20.9	24.3						
185	22.5	25.9						
240	25.0	28.4						
300	27.7	30.4						
Nominal voltage U₀/U 12/20 kV (K)								
35	18.3	20.5	501153	501154	501155			
50	19.5	21.7						
70	21.2	23.4						
95	22.8	25.0						
120	23.6	27.0						
150	25.1	28.5	501156	501157				
185	26.7	30.1						
240	29.2	32.6						
300	31.2	34.6						
Nominal voltage U₀/U 18/30 kV (M)								
50	23.8	26.7	501156	501157				
70	25.5	28.4						
95	27.1	30.0						
120	28.6	32.0						
150	30.1	33.5						
185	31.7	35.1	501156	501157				
240	34.2	37.6						
300	36.9	39.6						
Nominal voltage U₀/U 20.8/36 kV³⁾ (P)								
50	23.8	26.7				501156	501157	
70	25.5	28.4						
95	27.1	30.0						
120	28.6	32.0						
150	30.1	33.5						
185	31.7	35.1	501156	501157				
240	34.2	37.6						

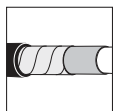

For use with copper tape screened cables.
 Order: Kit MT.



For use with other cable types please contact our representative.



For outdoor applications.

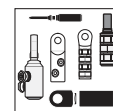

All accessories available with mechanical or compression conductor connector.



When installed on appropriate equipment bushing: 1250 A continuously.

484TB/G EUROMOLD® Compact tee connector for multiple voltage levels

Interface C

up to 42 kV, 630 A/1250 A¹⁾

Application

Suitable for installation on polymeric insulated medium voltage cables with extruded easy strip conductive screen or bonded extruded conductive screen. For use with other cable types please contact our sales representative.

Technical characteristics

- The thick conductive EPDM jacket provides a total safe to touch screen to ensure safety.
- For multiple voltage levels.
- For use with test rod 800TR/800TR-A.
- Each separable connector is tested for AC withstand and partial discharge prior to leaving the factory.

$U_0 / U (U_m)$
6/10 (12) kV
6.35/11 (12) kV
8.7/15 (17.5) kV
12/20 (24) kV
12.7/22 (24) kV
18/30 (36) kV
19/33 (36) kV
20.8/36 (42) kV

Design

1. Conductive EPDM insert
 2. Conductive EPDM jacket
 3. Insulating EPDM layer moulded between the insert and the jacket
 4. Type C - interface as described by CENELEC EN 50180 and 50181
 5. Bolted or crimp conductor contact
 6. Basic insulating plug (with voltage detection point)
 7. Cable reducer
 8. Conductive rubber cap
 9. Clamping screw M16 with spring washer and nut
 10. Earth lead
- The screen break design enables cable outer sheath testing without removing or dismantling the connector.

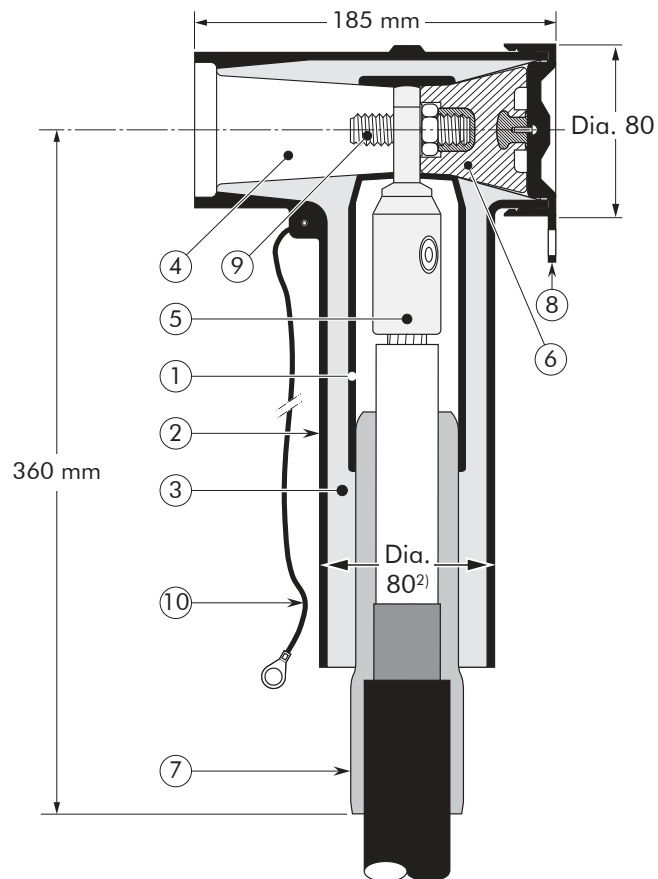

²⁾ The indicated diameter is a die dimension. Depending on the conductor cross-section used, a deviation of up to +5 mm is possible.

Specifications and standards

The 484TB/G separable connector meets the requirements of CENELEC HD 629.1. ATEX version can be delivered on request.

Separable connector type	Nominal voltage U_0 / U (kV)	Current I_n (A)	Conductor cross-section (mm ²)	
			min.	max.
484TB/G	6/10	630/1250 ¹⁾	240	630
K484TB/G	12/20	630/1250 ¹⁾	240	630
M484TB/G	18/30	630/1250 ¹⁾	240	630
P484TB/G	20.8/36	630/1250 ¹⁾	240	630

¹⁾ When installed on appropriate equipment bushing

Kit contents

The complete (K)(M)(P)484TB/G tee connector kit comprises 3 x the following components:

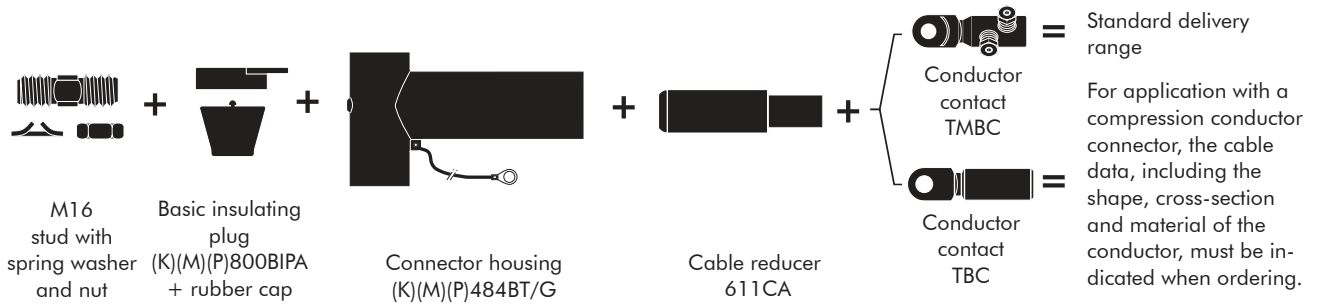

Ordering instructions

Indicate the part number for multirange application when ordering (see table).

Order example:

1 compact tee connector kit for 12/20 kV, for 240-400 mm² with mechanical conductor connector.

Order according to the table: K484TB/G with part number 57387.

Note: The classification does only apply for polymeric insulated XLPE cables (dimensions acc. to DIN VDE 0276 620) with extruded conductive screen and stranded conductors.

⁴⁾ Since the dimensions for cables at voltage level 20.8/36 (42) kV are not yet standardised, the conductor cross-sections and their assignment of diameters over core insulation given in the table are to be considered approximate values. When ordering accessories, we would like to ask you to indicate the checked diameters over core insulation.

Cross-section (mm ²) ³⁾	Dia. over core insulation (mm)		Multirange assignment Ordering part number for (K)(M)(P)484TB/G with mechanical connector TMBC	
	min.	max.		
Nominal voltage U₀/U 6/10 kV				
240	25.0	28.4	57381	
300	27.7	30.4		
400	30.9	33.6		57382
500	33.7	36.4		
630	37.1	40.8		57383
Nominal voltage U₀/U 12/20 kV (K)				
240	29.2	32.6	57387	
300	31.2	34.6		
400	34.4	37.8		57388
500	37.2	40.6		
630	41.3	45.0		57461
Nominal voltage U₀/U 18/30 kV (M)				
240	34.2	37.6	57391	
300	36.2	39.6		
400	39.4	42.8		57392
500	42.2	45.6		
630	46.3	50.0		
Nominal voltage U₀/U 20.8/36 kV⁴⁾ (P)				
240	34.2	37.6	57395	
300	36.2	39.6		
400	39.4	42.8		57396
500	42.2	45.6		
630	46.3	50.0		

³⁾ Other cross-sections available on request.

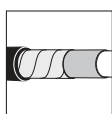

For use with copper tape screened cables.
Order: Kit MT.



For use with other cable types please contact our representative.



For outdoor applications.

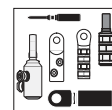

All accessories available with mechanical or compression conductor connector.



When installed on appropriate equipment bushing: 1250 A continuously.

804PB/G EUROMOLD® Coupling connector for 480TB/G, 484TB/G and 489TB/G

Interface C

up to 42 kV, 630 A/1250 A¹⁾

Application

Separable coupling connector 804PB/G for dual cable arrangement. It has been designed to be used with 480TB/G, 484TB/G or 489TB/G separable tee connector. The cable arrangement might be extended by multiple coupling connectors.

Technical characteristics

- A thick conductive EPDM jacket provides a total safe to touch screen.
- For use with test rod 800TR/800TR-A.
- Each separable connector is tested for AC withstand and partial discharge prior to leaving the factory.

$U_0 / U (U_m)$
6/10 (12) kV
6.35/11 (12) kV
8.7/15 (17.5) kV
12/20 (24) kV
12.7/22 (24) kV
18/30 (36) kV
19/33 (36) kV
20.8/36 (42) kV

Design

1. Interface designed to fit 480TB/G, 484TB/G or 489TB/G tee connector
 2. Bus for 804PB/G
 3. Bolted or crimp conductor contact
 4. Conductive EPDM insert
 5. Conductive EPDM jacket
 6. Insulating EPDM layer moulded between the insert and the jacket
 7. Cable reducer
 8. Conductive EPDM cap
 9. Basic insulating plug (with voltage detection point)
 10. Earth lead
- The screen break design enables cable outer sheath testing without removing or dismantling the connector.

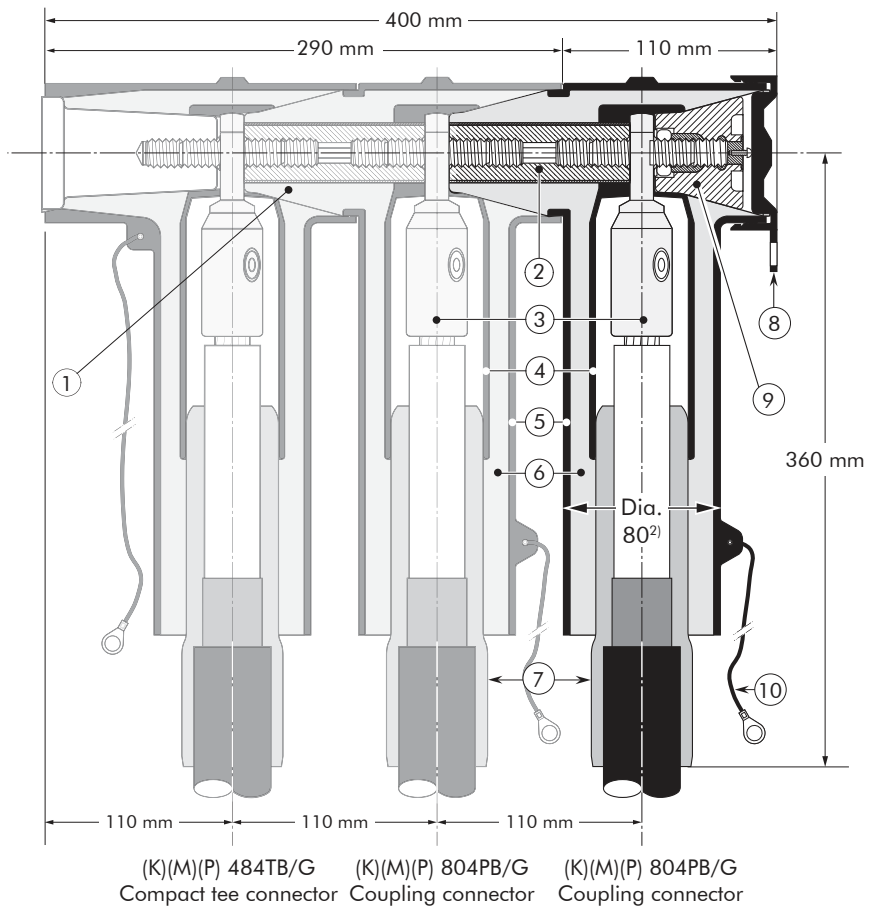

Specifications and standards

The 804PB/G coupling connector meets the requirements of CENELEC HD 629.1. ATEX version can be delivered on request.

²⁾ The indicated diameter is a die dimension. Depending on the conductor cross-section used, a deviation of up to +5 mm is possible.

Separable connector type	Nominal voltage U_0 / U (kV)	Current I_n (A)	Conductor cross-section (mm ²)	
			min.	max.
804PB/G	6/10	630/1250 ¹⁾	240	630
K804PB/G	12/20	630/1250 ¹⁾	240	630
M804PB/G	18/30	630/1250 ¹⁾	240	630
P804PB/G	20.8/36	630/1250 ¹⁾	240	630

¹⁾ When installed on appropriate equipment bushing.

Kit contents

The complete (K)(M)(P)804PB/G coupling connector kit comprises 3 x the following components:

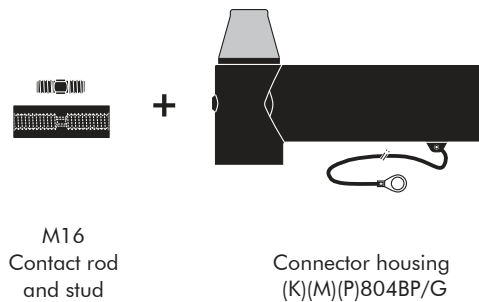

M16
Contact rod
and stud

Connector housing
(K)(M)(P)804PB/G

Cable reducer
611CA

The kit also comprises:
+ installation instructions
+ silicone grease
+ wipers
+ screen wire cable lugs



Conductor
contact TMBC

= Standard delivery
range



Conductor
contact TBC

= For application with a
compression conductor
connector, the cable
data, including the
shape, cross-section
and material of the
conductor, must be in-
dicated when ordering.

Ordering instructions

Indicate the part number for multirange application when ordering (see table).

Order example:

1 coupling connector for 12/20 kV, for 240-400 mm² with mechanical conductor connector.

Order according to the table: K804PB/G with part number 57405.

Note: The classification does only apply for polymeric insulated XLPE cables (dimensions acc. to DIN VDE 0276 620) with extruded conductive screen and stranded conductors.

⁴⁾ Since the dimensions for cables at voltage level 20.8/36 (42) kV are not yet standardised, the conductor cross-sections and their assignment of diameters over core insulation given in the table are to be considered approximate values. When ordering accessories, we would like to ask you to indicate the checked diameters over core insulation.

Cross-section (mm ²) ³⁾	Dia. over core insulation (mm)		Multirange assignment	
	min.	max.	Ordering part number for (K)(M)(P)804PB/G	
Nominal voltage U₀/U 6/10 kV				
240	25.0	28.4	57399	
300	27.7	30.4		
400	30.9	33.6		57400
500	33.7	36.4		
630	37.1	40.8		57401
Nominal voltage U₀/U 12/20 kV (K)				
240	29.2	32.6	57405	
300	31.2	34.6		
400	34.4	37.8		57406
500	37.2	40.6		
630	41.3	45.0		57462
Nominal voltage U₀/U 18/30 kV (M)				
240	34.2	37.6	57409	
300	36.2	39.6		
400	39.4	42.8		
500	42.2	45.6		57410
630	46.3	50.0		
Nominal voltage U₀/U 20.8/36 kV⁴⁾ (P)				
240	34.2	37.6	57413	
300	36.2	39.6		
400	39.4	42.8		
500	42.2	54.6		57414
630	46.3	50.0		

³⁾ Other cross-sections available on request.

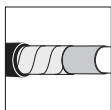

For use with
copper tape
screened cables.
Order: Kit MT.



For use with
other cable types
please contact our
representative.



For outdoor
applications.

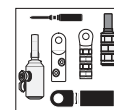

All accessories available
with mechanical or
compression conductor
connector.



When installed on
appropriate equipment
bushing: 1250 A
continuously.

489TB/G EUROMOLD® Compact tee connector for multiple voltage levels

Interface C

up to 42 kV, 630 A/1250 A¹⁾

Application

Suitable for installation on polymeric insulated medium voltage cables with extruded easy strip conductive screen or bonded extruded conductive screen. For use with other cable types please contact our sales representative.

Technical characteristics

- The thick conductive EPDM jacket provides a total safe to touch screen to ensure safety.
- For multiple voltage levels.
- For use with test rod 800TR/800TR-A.
- Each separable connector is tested for AC withstand and partial discharge prior to leaving the factory.

$U_0 / U (U_m)$
6/10 (12) kV
6.35/11 (12) kV
8.7/15 (17.5) kV
12/20 (24) kV
12.7/22 (24) kV
18/30 (36) kV
19/33 (36) kV
20.8/36 (42) kV

Design

1. Conductive EPDM insert
2. Conductive EPDM jacket
3. Insulating EPDM layer moulded between the insert and the jacket
4. Type C - interface as described by CENELEC EN 50180 and 50181
5. Bolted or crimp conductor contact
6. Basic insulating plug (with voltage detection point)
7. Cable reducer
8. Conductive rubber cap
9. M16 Clamping screw with spring washer and nut
10. Earth lead

The screen break design enables cable outer sheath testing without removing or dismantling the connector.

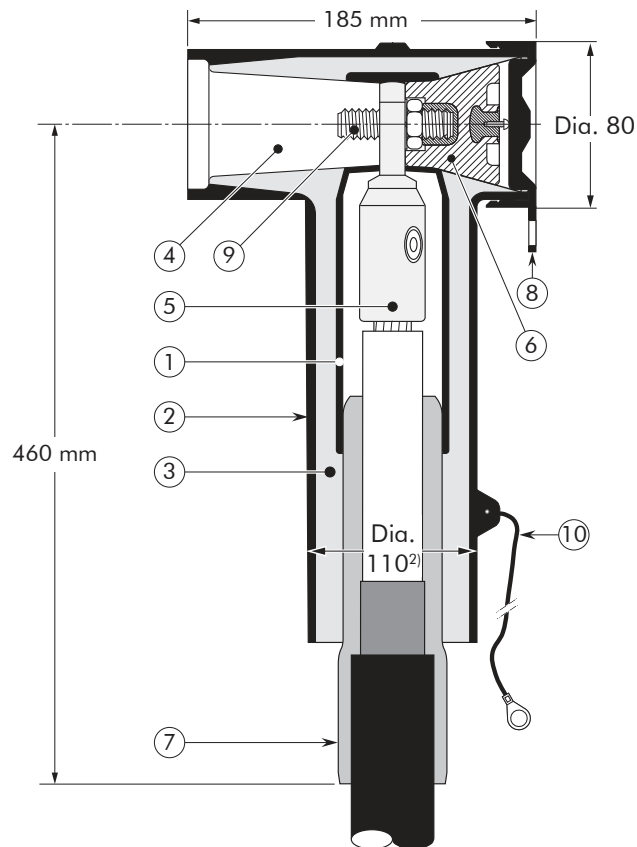

²⁾ The indicated diameter is a die dimension. Depending on the conductor cross-section used, a deviation of up to +5 mm is possible.

Specifications and standards

The 489TB/G separable connector meets the requirements of CENELEC HD 629.1.

Separable connector type	Nominal voltage U_0 / U (kV)	Current I_n (A)	Conductor cross-section (mm ²)	
			min.	max.
489TB/G	6/10	630/1250 ¹⁾	800	1200
K489TB/G	12/20	630/1250 ¹⁾	800	1200
M489TB/G	18/30	630/1250 ¹⁾	800	1200
P489TB/G	20.8/36	630/1250 ¹⁾	800	1200

¹⁾ When installed on appropriate equipment bushing.

Kit contents

The complete (K)(M)(P)489TB/G tee connector kit comprises 3 x the following components:

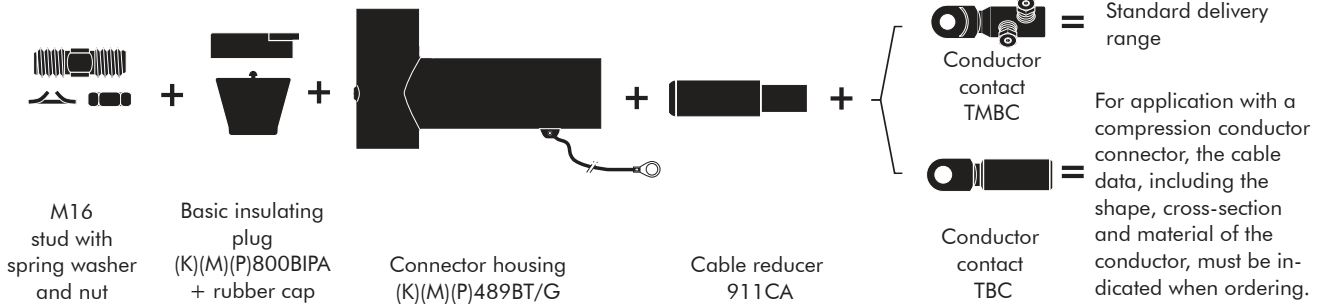

Ordering instructions

Indicate the part number for multirange application when ordering (see table).

Order example:

1 compact tee connector kit for 12/20 kV, for 800 mm² with mechanical conductor connector. Order according to the table: K489TB/G with part number 57200.

Note:

The classification does only apply for polymeric insulated XLPE cables (dimensions acc. to DIN VDE 0276 620) with extruded conductive screen and stranded conductors.

⁴⁾ Since the dimensions for cables at voltage level 20.8/36 (42) kV are not yet standardised, the conductor cross-sections and their assignment of diameters over core insulation given in the table are to be considered approximate values. When ordering accessories, we would like to ask you to indicate the checked diameters over core insulation.

Cross-section (mm ²) ³⁾	Dia. over core insulation (mm)		Article classification Ordering part number for (K)(M)(P)489TB/G	
	min.	max.	with mechanical connector TMBC	
Nominal voltage U₀/U 6/10 kV				
800	40.0	44.6	57199	
1000	43.8	48.0	On request	
1200			On request	
Nominal voltage U₀/U 12/20 kV (K)				
800	44.2	48.0	57200	
1000	47.8	52.8		57201
1200			On request	
Nominal voltage U₀/U 18/30 kV (M)				
800	49.2	53.8	57202	
1000	53.0	57.8		57203
1200			On request	
Nominal voltage U₀/U 20.8/36 kV⁴⁾ (P)				
800	49.2	53.8	57204	
1000	53.0	57.8		57205
1200			On request	

³⁾ Other cross-sections available on request.

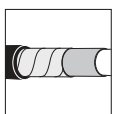

For use with copper tape screened cables.
Order: Kit MT.

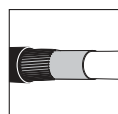

For use with copper wire screened cables no earthing device is necessary.



For use with other cable types please contact our representative.



For outdoor applications.



Components can be ordered individually.



When installed on appropriate equipment bushing: 1250 A continuously.

809PB/G EUROMOLD® Coupling connector for 480TB/G, 484TB/G and 489TB/G

Interface C

up to 42 kV, 630 A/1250 A¹⁾

Application

Separable coupling connector 809PB/G for dual cable arrangement. It has been designed to be used with 480TB/G, 484TB/G or 489TB/G separable tee connector. The cable arrangement might be extended by multiple coupling connectors.

Technical characteristics

- A thick conductive EPDM jacket provides a total safe to touch screen.
- Each separable connector is tested for AC withstand and partial discharge prior to leaving the factory.

$U_0 / U (U_m)$
6/10 (12) kV
12/20 (24) kV
18/30 (36) kV
20.8/36 (42) kV

Design

1. Interface designed to fit 480TB/G, 484TB/G and 489TB/G tee connector
2. Bus for 809PB/G
3. Bolted or crimp conductor contact
4. Conductive EPDM insert
5. Conductive EPDM jacket
6. Insulating EPDM layer moulded between the insert and the jacket
7. Cable reducer
8. Conductive rubber cap
9. Basic insulating plug (with voltage detection point)
10. Earth lead

The screen break design enables cable outer sheath testing without removing or dismantling the connector.

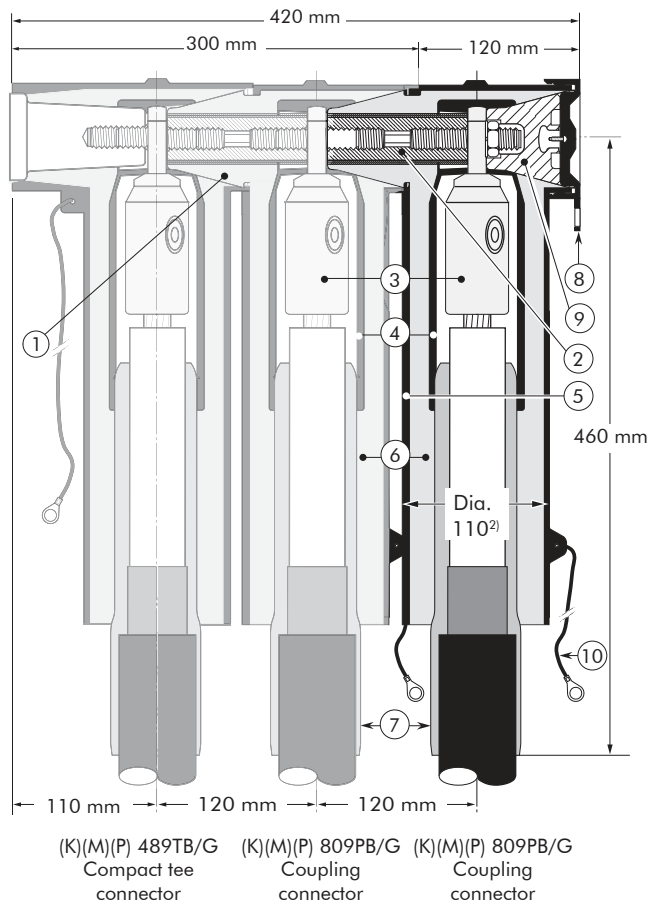

Specifications and standards

The 809PB/G coupling connector meets the requirements of CENELEC HD 629.1.

²⁾ The indicated diameter is a die dimension. Depending on the conductor cross-section used, a deviation of up to +5 mm is possible.

Separable connector type	Nominal voltage U_0 / U (kV)	Current I_n (A)	Conductor cross-section (mm ²)	
			min.	max.
809PB/G	6/10	630/1250 ¹⁾	800	1200
K809PB/G	12/20	630/1250 ¹⁾	800	1200
M809PB/G	18/30	630/1250 ¹⁾	800	1200
P809PB/G	20.8/36	630/1250 ¹⁾	800	1200

¹⁾ When installed on appropriate equipment bushing.

Kit contents

The complete (K)(M)(P)809PB/G coupling connector kit comprises 3 x the following components:

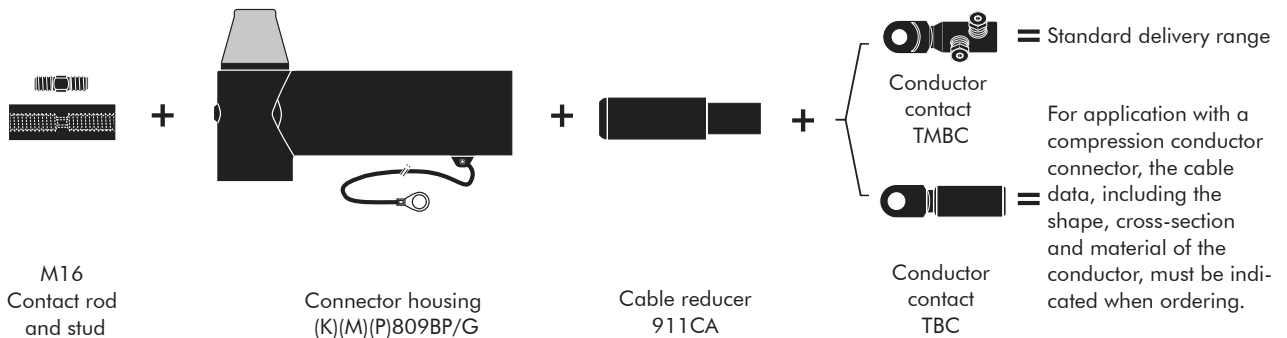

Ordering instructions

Indicate the part number for multirange application when ordering (see table).

Order example:

1 coupling connector kit for 12/20 kV, for 800 mm² with mechanical conductor connector.

Order according to the table: K809PB/G with part number 57207.

Note:

The classification does only apply for polymeric insulated XLPE cables (dimensions acc. to DIN VDE 0276 620) with extruded conductive screen and stranded conductors.

⁴⁾ Since the dimensions for cables at voltage level 20.8/36 (42) kV are not yet standardised, the conductor

Cross-section (mm ²) ³⁾	Dia. over core insulation (mm)		Article classification Ordering part number for (K)(M)(P)809PB/G	
	min.	max.	with mechanical connector TMBC	
Nominal voltage U₀/U 6/10 kV				
800	40.0	44.6	57206	
1000	43.8	48.0	On request	
1200			On request	
Nominal voltage U₀/U 12/20 kV (K)				
800	44.2	48.0	57207	
1000	47.8	52.8	57208	
1200			On request	
Nominal voltage U₀/U 18/30 kV (M)				
800	49.2	53.8	57209	
1000	53.0	57.8	57210	
1200			On request	
Nominal voltage U₀/U 20.8/36 kV⁴⁾ (P)				
800	49.2	53.8	57211	
1000	53.0	57.8	57212	
1200			On request	

³⁾ Other cross-sections available on request.

cross-sections and their assignment of diameters over core insulation given in the table are to be considered approximate values. When ordering accessories, we would like to ask you to indicate the checked diameters over core insulation.

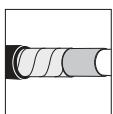

For use with copper tape screened cables.
Order: Kit MT.

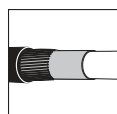

For use with copper wire screened cables no earthing device is necessary.



For use with other cable types please contact our representative.



For outdoor applications.



When installed on appropriate equipment bushing: 1250 A continuously.

800SA EUROMOLD® Surge arrester for 480TB/G, 484TB/G and 489TB/G Compact tee connector

Interface C

up to 42 kV, 630 A/1250 A

Application

Surge arrester 800SA designed to protect 12, 24, 36 and 42 kV class components, including transformers, equipment, cable and accessories from high voltage surges resulting from lightning or switching.

Technical characteristics

- This metal oxide varistor has been designed to be used in combination with 480TB/G, 484TB/G and 489TB/G separable tee connector, 800PB/G, 804PB/G and 809PB/G coupling connector or 480BE/G bushing extender.
- Each arrester is tested for AC withstand prior to leaving the factory.

$U_0 / U (U_m)$
6/10 (12) kV
6.35/11 (12) kV
8.7/15 (17.5) kV
12/20 (24) kV
12.7/22 (24) kV
18/30 (36) kV
19/33 (36) kV
20.8/36 (42) kV

Design

1. Conductive EPDM insert
2. Conductive EPDM jacket
3. Insulating EPDM layer
4. Receptacle for contact rod
5. Metal oxide valve elements
6. Steel cap
7. Earth connection
8. Earth lead
9. Interface designed to fit 480TB/G, 484TB/G and 489TB/G tee connector, 800PB/G, 804PB/G and 809PB/G coupling connector or 480BE/G bushing extender

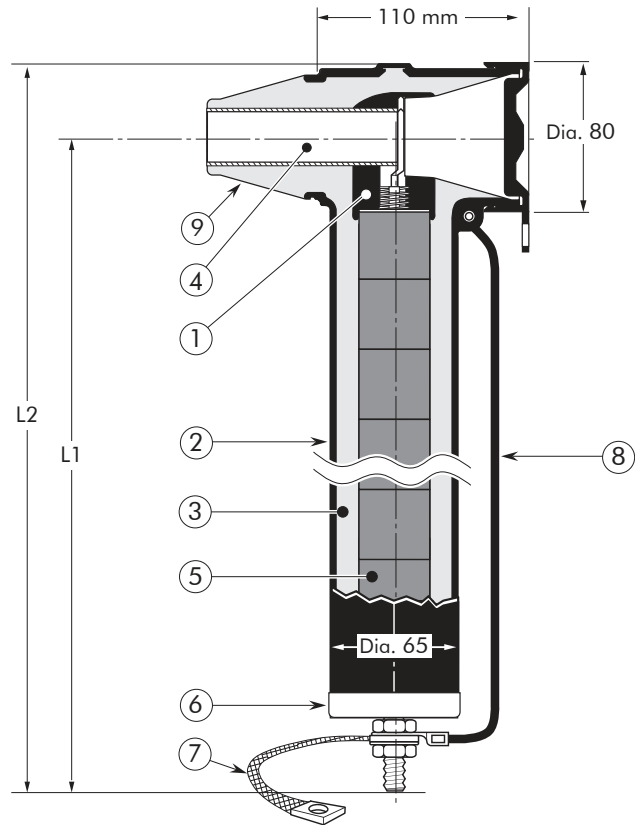

Specifications and standards

The 800SA surge arrester meets the test requirements of IEC 60099-4.

ATEX version can be delivered on request.

Ordering instructions

Indicate the type of surge arrester when ordering (see table). The part numbers each apply to one kit consisting of three surge arresters.

Order example:

For a max. operating voltage of 24 kV and a nominal discharge current of 10 kA, order according to the table: Surge arrester type 800SA-10-30N with part number 85813.

Note:

The order information only applies to the use in compensated, high-impedance networks.

Products for divergent parameters available on request.

Surge arrester type	Nominal discharge current I_n (kA)	Rated voltage ¹⁾ U_r (kV)	Max. continuous operating voltage U_c (kV)	High current impulse withstand (kA)	Dimensions (mm)		Ordering part number
					L1	L2	
800SA-10-6N	10	6	4.8	100	250	290	85801
800SA-10-9N	10	9	7.2	100	250	290	85803
800SA-10-12N	10	12	9.6	100	250	290	85805
800SA-10-15N	10	15	12.0	100	250	290	85807
800SA-10-18N	10	18	14.4	100	250	290	85809
800SA-10-22N	10	22	17.6	100	250	290	87149
800SA-10-24N	10	24	19.2	100	350	390	85811
800SA-10-30N	10	30	24.0	100	350	390	85813
800SA-10-33N	10	33	26.4	100	350	390	86998
800SA-10-36N	10	36	28.8	100	350	390	85815
800SA-10-42N	10	42	33.6	100	450	490	85817
800SA-10-45N	10	45	36.0	100	450	490	85819
800SA-10-51N	10	51	40.8	100	450	490	87147

¹⁾ Surge arresters for other rated voltages available on request.

Typical application and dimensions

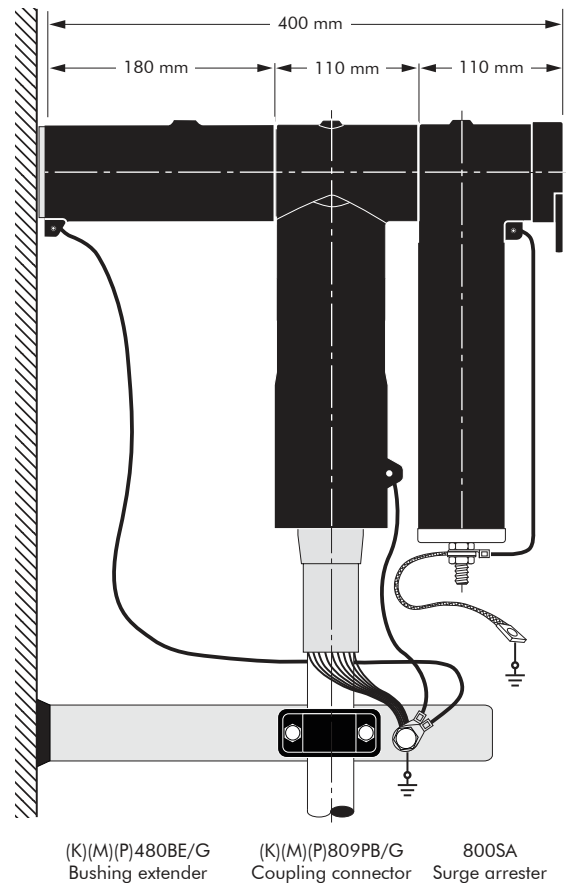
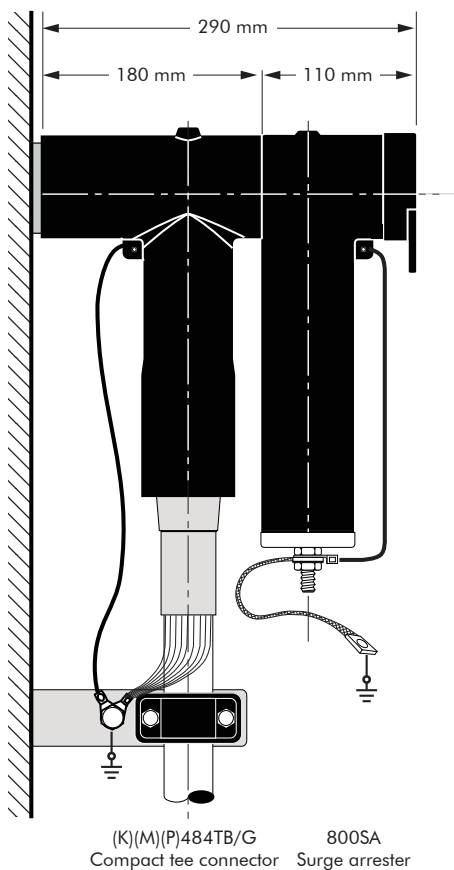

480BE/G EUROMOLD® Asymmetrical bushing extender

Interface C

up to 42 kV, 1250 A¹⁾

Application

The separable bushing extender with earth lead provides an extension piece to allow cables to stand away from equipment. It has been designed to be used in combination with coupling connector 800PB/G, 804PB/G or 809PB/G.

Technical characteristics

- The thick conductive EPDM jacket provides a total safe to touch screen to ensure safety.
- Each bushing extender is tested for AC withstand and partial discharge prior to leaving the factory.

$U_0 / U (U_m)$
6/10 (12) kV
6.35/11 (12) kV
8.7/15 (17,5) kV
12/20 (24) kV
12.7/22 (24) kV
18/30 (36) kV
20.8/36 (42) kV

Design

1. Conductive EPDM insert
2. Conductive EPDM jacket
3. Insulating EPDM layer moulded between the insert and the jacket
4. Type C1 + C2 - interface as described by CENELEC EN 50180 and 50181
5. Earth lead

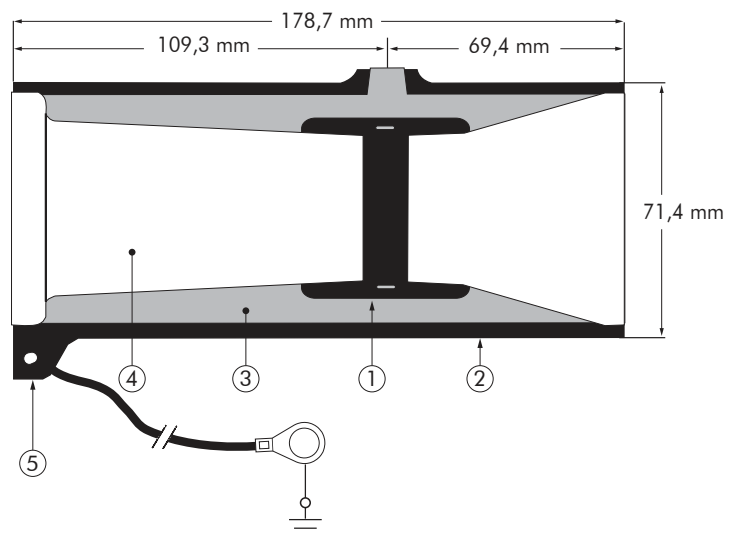

For use with coupling connectors with compact plug and interface C equipment bushing as described by CENELEC EN 50180 and EN 50181.

Specifications and standards

The 480BE/G bushing extender meets the requirements of CENELEC HD 629.1.

Asymmetrical bushing extender type	Nominal voltage U_0/U (kV)	Current I_n (A)
480BE/G	6/10	1250 ¹⁾
K480BE/G	12/20	1250 ¹⁾
M480BE/G	18/30	1250 ¹⁾
P480BE/G	20.8/36	1250 ¹⁾

¹⁾ When installed on appropriate equipment bushing.

400TR/800TR/800TR-A EUROMOLD® Test rod for cable testing

Interface C

Application

The test rod can be used as galvanic contact to the conductor for cable fault location, cable testing, phasing checks etc. The test lead may be connected by cable lug or insulated test pins.

Technical characteristics

Use 400TR for the following connector types:

- Tee connector 400TE
- Tee connector 400TB/G
- Tee connector 440TB/G
- Coupling connector 440PB/G
- Compact tee connector 430TB/G
- Coupling connector 300PB/G

Use 800TR for the following connector types:

- Compact tee connector 480TB/G, 484TB/G and 489TB/G
- Coupling connector 800PB/G, 804PB/G and 809PB/G

Design

1. Conductive EPDM insulating shroud
2. Threaded rod for test connection
3. M12 nuts for connecting the test lead
4. Insulation
5. Copper test rod stem

Installation

The test rod is screwed into the connector instead of the basic insulating plug. Then the test lead is connected to the threaded stem and the insulating shroud moved to its final position.

Ordering instructions

Simply specify test rod 400TR, 800TR or screwed adapter 800TR-A

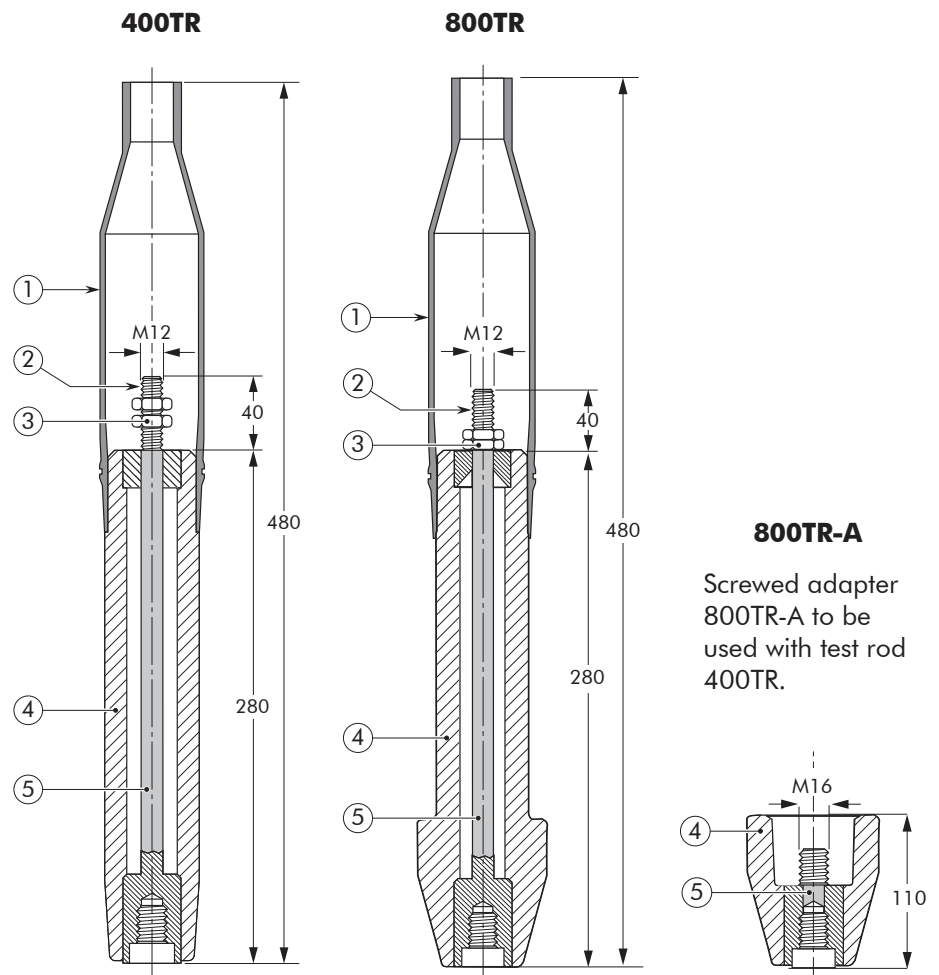

Test rod type	Maximum AC test voltage (50 Hz - 1 min)	Maximum DC test voltage (8 x U ₀ - 30 min)	Impulse voltage (1.2 x 50 μs) min	Ordering part number
400TR	36 kV	96 kV	95 kV	70126
800TR	36 kV	96 kV	95 kV	85830
800TR-A	36 kV	96 kV	95 kV	87493

15-01-2019

POSSIBLE ARRANGEMENTS

Interface C

480TB/G
Single cable arrangement

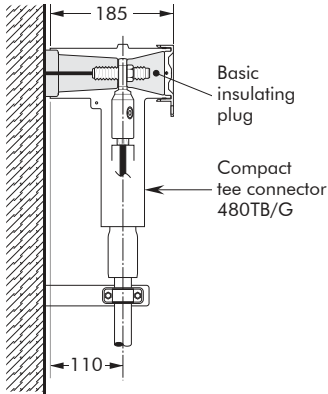

480TB/G-P2
Dual cable arrangement

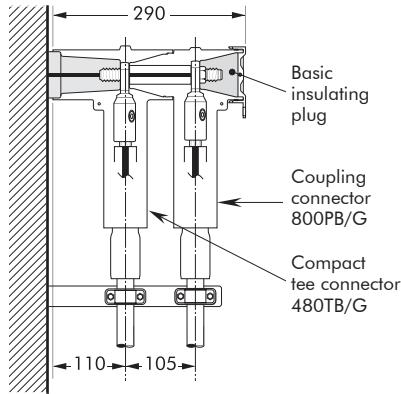

480TB/G-P2 + 800SA
Dual cable arrangement with surge arrester

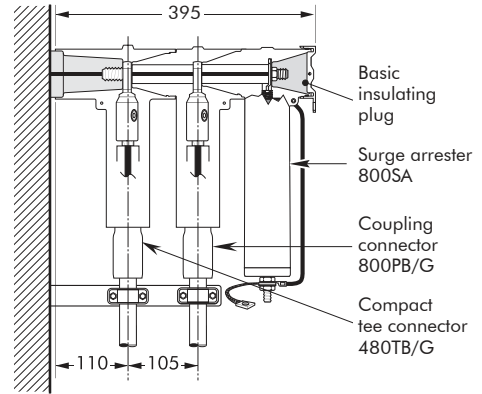

484TB/G
Single cable arrangement

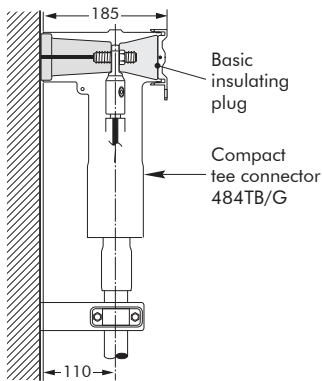

484TB/G-P2
Dual cable arrangement

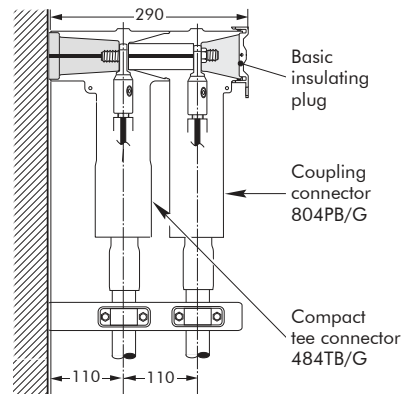

484TB/G-P2 + 800SA
Dual cable arrangement with surge arrester

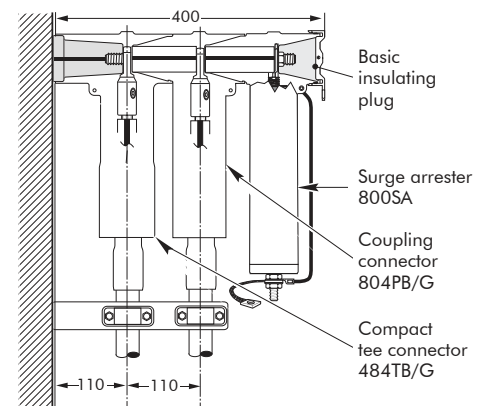

489TB/G
Single cable arrangement

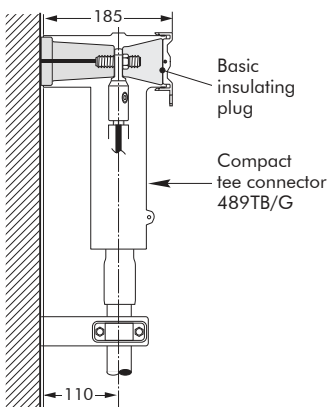

489TB/G-P2
Dual cable arrangement

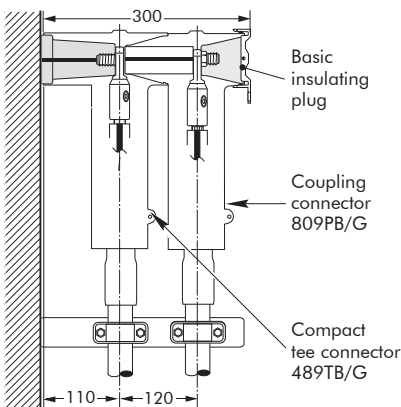

489TB/G-P2 + 800SA
Dual cable arrangement with surge arrester

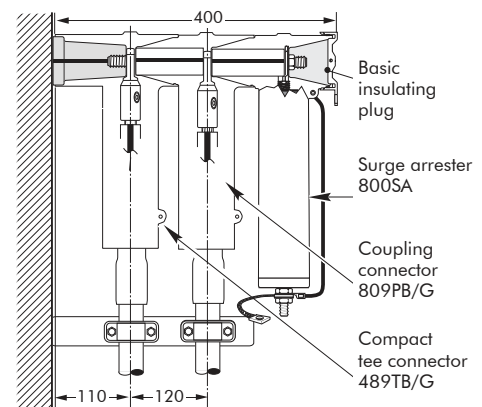

CONNECTING POSSIBILITIES EUROMOLD® BOLTED CONNECTOR SYSTEM

Interface C

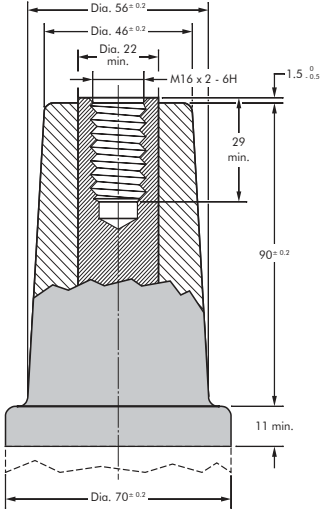

Interface C1+C2
630 A / 1250 A outer cone
acc. to CENELEC EN 50180
and EN 50181

$U_0 / U (U_m)$
6/10 (12) kV
6.35/11 (12) kV
8.7/15 (17.5) kV
12/20 (24) kV
12.7/22 (24) kV
18/30 (36) kV
19/33 (36) kV
20.8/36 (42) kV

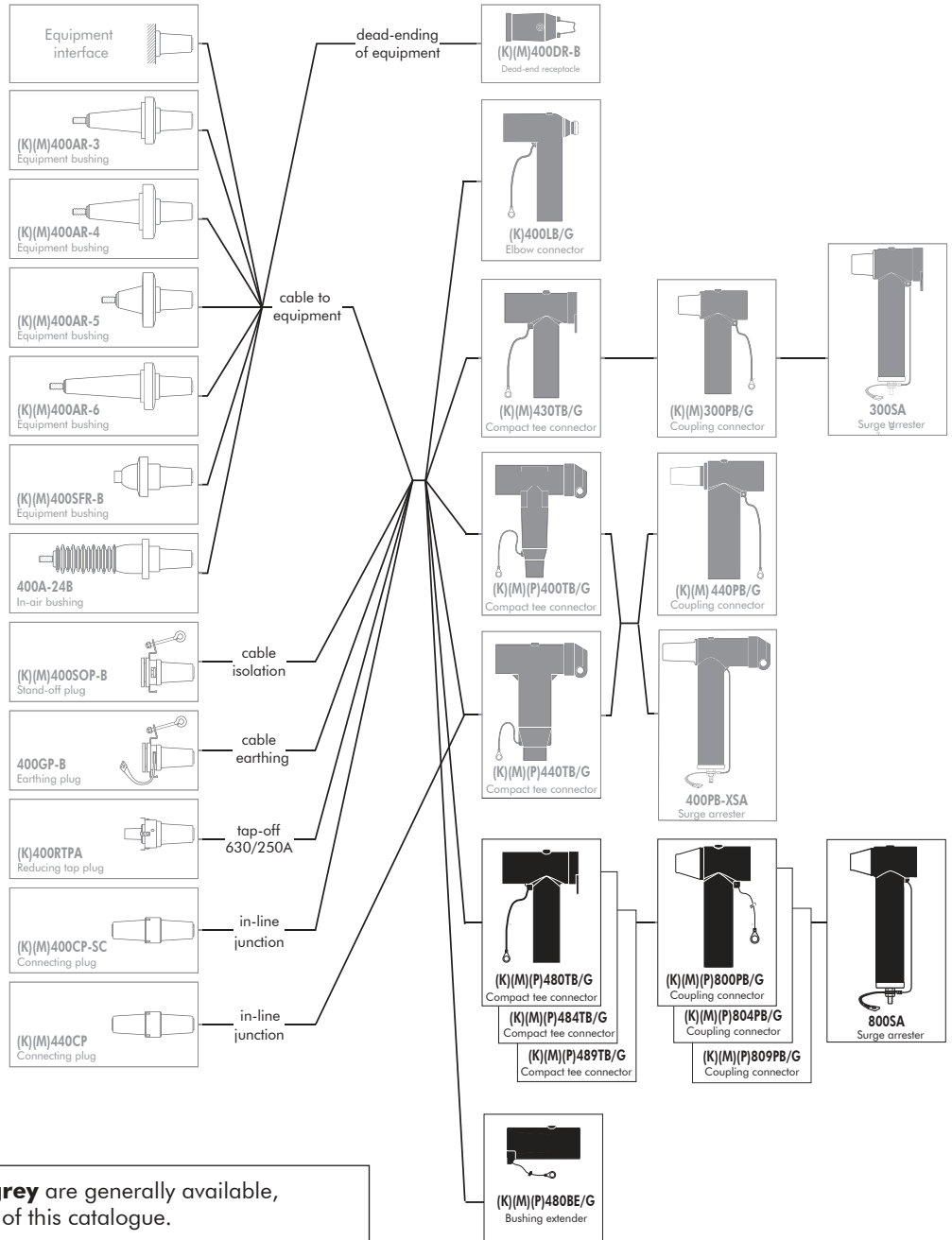

Products displayed in **grey** are generally available,
but not part of this catalogue.



SLIP-ON TERMINATIONS

up to 42 kV



AIS

Indoor slip-on termination

up to 24 kV

Application

The AIS 20 termination is suitable for indoor installation on polymeric insulated medium voltage cables with extruded easy strip conductive screen or bonded extruded conductive screen. With this high quality silicone termination, a wide range of cross-sections is covered per voltage level.

Another benefit given by using the AIS termination is the quick and easy assembly. The conductor can be connected with mechanical cable lugs. The termination is available with additional splitting accessories for three-core, copper wire screened or copper tape screened and armored cables.

$U_0 / U (U_m)$

6/10 (12) kV
 6.35/11 (12) kV
 8.7/15 (17.5) kV
 12/20 (24) kV
 12.7/22 (24) kV

Design

1. Longitudinally sealed mechanical cable lug
2. Integrated silicone tube as sealing element when using mechanical cable lugs
3. High flexibility silicone rubber housing, ensuring a perfect fit to the cable even during load changes
4. Integrated conductive rubber insert
5. Earth cable lug
6. Heat-shrinkable tube
7. Heat-shrinkable break-out

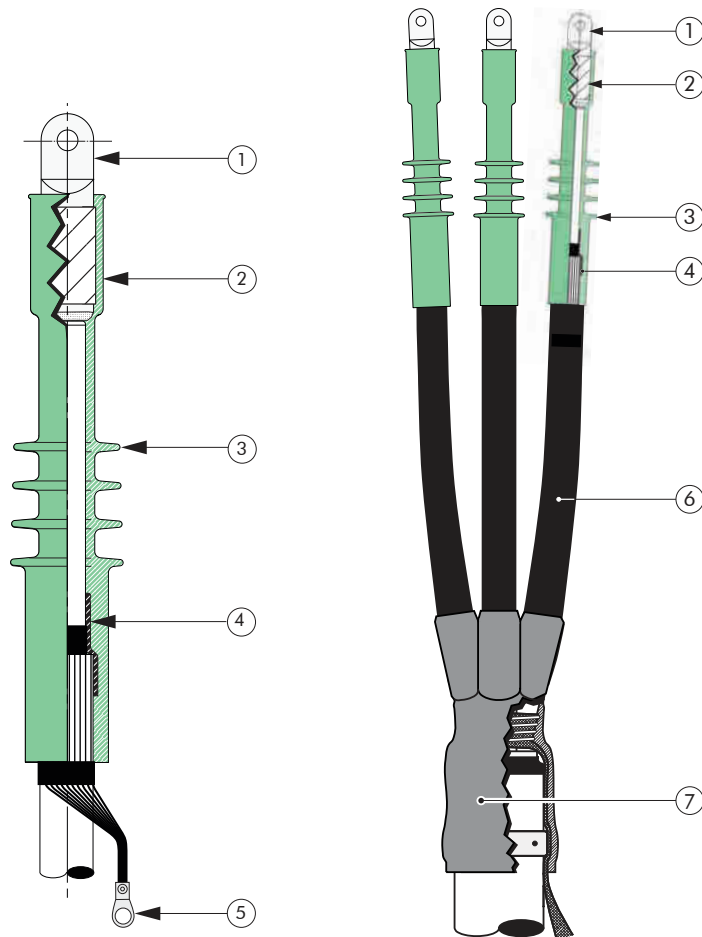

Specifications and standards

Meets the requirements of CENELEC HD 629.1

Termination type	Nominal voltage U_0 / U (kV)	Conductor cross-section (mm ²) ¹⁾	
		min.	max.
AIS 20	6/10	150	300 ²⁾
AIS 20	12/20	70	300 ²⁾

¹⁾ Other cross-sections are available on request.

²⁾ When using mechanical cable lugs for conductor cross-section greater than 240 mm², an additional sealing element is required.

Kit contents

- 3 termination housings
- 3 mechanical cable lugs for the conductor
- 3 mechanical screen wire cable lugs
- Installation instructions
- Silicone grease
- Assembly incidentals
- Additional sealing element for 300 mm² application

Ordering instructions

Indicate the part number when ordering (see table).

Order example:

1 AIS 20 kit for 12/20 kV, for 70-240 mm² with mechanical cable lug (palm hole diameter 13 mm).

Order according to table 2:
1 kit – AIS 20 with part number 500027.

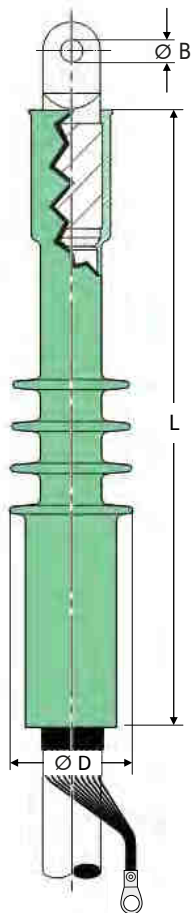

Table 1 - Classification and dimensions

Nominal voltage U_0/U (kV)	Conductor cross-section (mm ²)		Dia. over core insulation (mm)		Number of sheds	L (mm)	Dia. D ³⁾ (mm)	Termination type
	min.	max.	min.	max.				
6/10	150	240	20.9	35.0	4	270	53	AIS 20
	150	300						
12/20	70	240	20.9	35.0	4	270	53	AIS 20
	95	300						

Table 2 - Ordering part number

Conductor cross-section (mm ²)	Dia. over core insulation (mm)		Ordering part number (1 Kit = 3 Items) with mechanical cable lug		Termination type (Kit)
	min.	max.	Dia. B=13 mm	Dia. B=17 mm	
Nominal voltage $U_0/U (U_m)$ 6/10 (12) kV					
150	20.9	35.0	500025	500293	AIS 20
185					
240					
150	20.9	35.0	500292 ⁴⁾	500026 ⁴⁾	AIS 20
185					
240					
300	20.9	35.0	500027	500268	AIS 20
150					
185					
240	20.9	35.0	500294 ⁴⁾	500028 ⁴⁾	AIS 20
95					
120					
150	20.9	35.0	500294 ⁴⁾	500028 ⁴⁾	AIS 20
185					
240					
300	20.9	35.0	500294 ⁴⁾	500028 ⁴⁾	AIS 20
95					
120					

³⁾ The indicated diameter is a mould dimension. Depending on the conductor cross-section used, a deviation of up to +5 mm is possible.

⁴⁾ Supplied with additional sealing element.

Note: The classification does only apply for polymeric insulated XLPE cables (dimensions acc. to DIN VDE 0276 620) with extruded conductive screen and stranded conductors. Please contact our sales representative, when using other cable types.

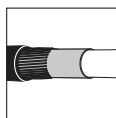

For use with copper wire screened cables no earthing device is necessary.

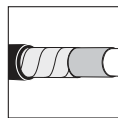

For use with copper tape screened cables.
Order : KIT MT.

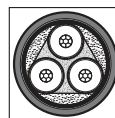

For use with three-core cables please contact our representative.



For use with other cable types please contact our representative.

AIP Indoor slip-on termination

up to 24 kV

Application

The AIP 20 termination is suitable for indoor installation on polymeric insulated medium voltage cables with extruded easy strip conductive screen or bonded extruded conductive screen. With this high quality silicone termination, a wide range of cross-sections is covered per voltage level.

Another benefit given by using the AIP termination is the quick and easy assembly. The conductor can be connected with compression cable lugs. The termination is available with additional splitting accessories for three-core, copper wire screened or copper tape screened and armored cables.

$U_0 / U (U_m)$
6/10 (12) kV
6.35/11 (12) kV
8.7/15 (17.5) kV
12/20 (24) kV
12.7/22 (24) kV

Design

1. Longitudinally sealed compression cable lug
2. High flexibility silicone rubber housing, ensuring a perfect fit to the cable even during load changes
3. Integrated conductive rubber insert
4. Earth cable lug
5. Heat-shrinkable tube
6. Heat-shrinkable break-out

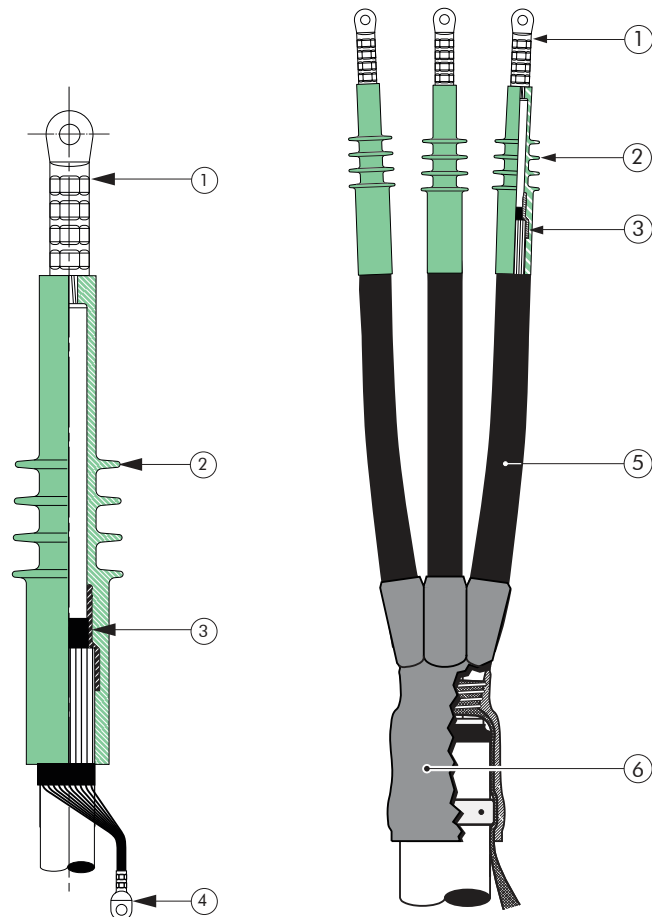

Specifications and standards

Meets the requirements of CENELEC HD 629.1

Termination type	Nominal voltage U_0 / U (kV)	Conductor cross-section (mm ²) ¹⁾	
		min.	max.
AIP 20	6/10	70	150
AIP 20	12/20	25	120

¹⁾ Other cross-sections are available on request.

Kit contents

- 3 termination housings
- 3 compression cable lugs for the conductor
- 3 compression screen wire cable lugs
- Installation instructions
- Silicone grease
- Assembly incidentals

Ordering instructions

Indicate the part number when ordering (see table).

Order example:

1 AIP 20 kit for 12/20 kV, for 70 mm² with compression cable lug (palm hole diameter 13 mm).

Order according to table 2:
1 kit – AIP 20 with part number 500011.

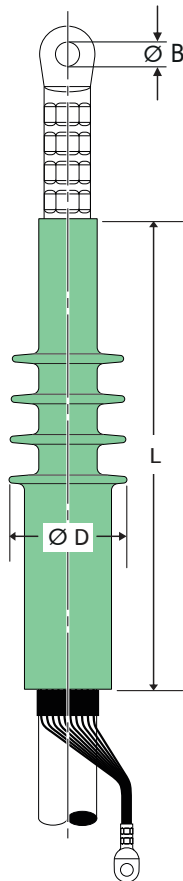

Table 1 - Classification and dimensions

Nominal voltage U_0/U (kV)	Conductor cross-section (mm ²)		Dia. over core insulation (mm)		Number of sheds	L (mm)	Dia. D ³⁾ (mm)	Termination type
	min.	max.	min.	max.				
6/10	70	150	17.0	27.0	4	230	49	AIP 20
12/20	25	120						

Table 2 - Ordering part number

Conductor cross-section (mm ²)	Dia. over core insulation (mm)		Ordering part number (1 Kit = 3 Items)			Termination type (Kit)
			with compression cable lug			
	min.	max.	Al-rm(V)	Cu-rm(V)	Dia. B (mm)	
Nominal voltage U_0/U (U_m) 6/10 (12) kV						
70	17.0	27.0	500004	500014	13	AIP 20
95			500005	500015		
120			500006	500016		
150			500007	500017		
Nominal voltage U_0/U (U_m) 12/20 (24) kV						
25 ²⁾	17.0	27.0	500008	500018	13	AIP 20
35			500009	500019		
50			500010	500020		
70			500011	500021		
95			500012	500022		
120			500324	500325		

²⁾ Cross-section 25 mm² according to DIN VDE 0276-620 unavailable.

³⁾ The indicated diameter is a mould dimension. Depending on the conductor cross-section used, a deviation of up to +5 mm is possible.

Note: The classification does only apply for polymeric insulated XLPE cables (dimensions acc. to DIN VDE 0276 620) with extruded conductive screen and stranded conductors. Please contact our sales representative, when using other cable types.

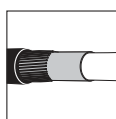

For use with copper wire screened cables no earthing device is necessary.

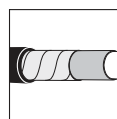

For use with copper tape screened cables.
Order : KIT MT.

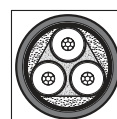

For use with three-core cables please contact our representative.



For use with other cable types please contact our representative.

AIN

Indoor slip-on termination

up to 24 kV

Application

AIN 10, AIN 20, AIN 30 and AIN 36 terminations are suitable for indoor installation on polymeric insulated medium voltage cables with extruded easy strip conductive screen or bonded extruded conductive screen. With this high quality silicone termination, the entire range of cross-sections is covered with just a few sizes

per voltage level. Another benefit given by using the AIN termination is the quick and easy assembly. The conductor can be alternatively connected with mechanical or compression cable lugs. The termination is available with additional splitting accessories for three-core, copper wire screened or copper tape screened and armored cables.

$U_0 / U (U_m)$
6/10 (12) kV
6.35/11 (12) kV
8.7/15 (17.5) kV
12/20 (24) kV
12.7/22 (24) kV
18/30 (36) kV
19/33 (36) kV
20.8/36 (42) kV

Design

1. Longitudinally sealed mechanical or compression cable lug
2. Silicone tube or cap as additional sealing at the transition of cable lug to the termination housing when using mechanical cable lugs
3. High flexibility silicone rubber housing, ensuring a perfect fit to the cable even during load changes
4. Integrated conductive rubber insert
5. Earth cable lug
6. Heat-shrinkable tube
7. Heat-shrinkable break-out

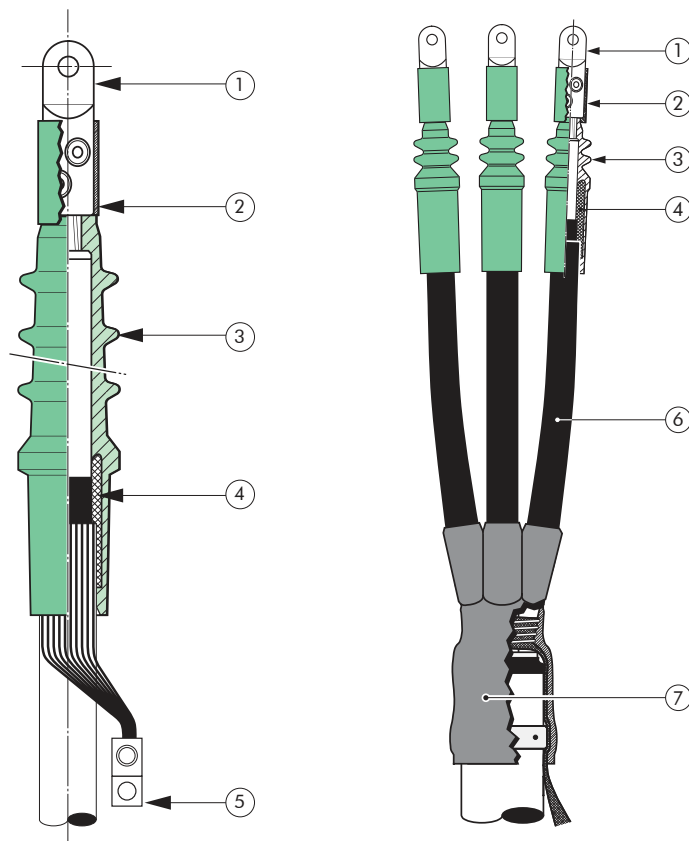

Specifications and standards

Meets the requirements of CENELEC HD 629.1

Termination type	Nominal voltage U_0 / U (kV)	Conductor cross-section (mm ²) ¹⁾	
		min.	max.
AIN 10	6/10	25	1000 (1200)
AIN 20	12/20	35	1000 (1200)
AIN 30	18/30	50	1000 (1200)
AIN 36	20.8/36	150	1000 (1200)

¹⁾ Other cross-sections are available on request.

Kit contents

- 3 termination housings
- 3 mechanical or compression cable lugs for the conductor
- 3 mechanical or compression screen wire cable lugs
- Installation instructions
- Silicone grease
- Assembly incidentals

Ordering instructions

Indicate the part number when ordering (see table).

Order example:

1 AIN 20 kit for 12/20 kV, for 95-240 mm² with mechanical cable lug (palm hole diameter 13 mm).

Order according to table 2:

1 kit – AIN 20 size 2 with part number 49756.

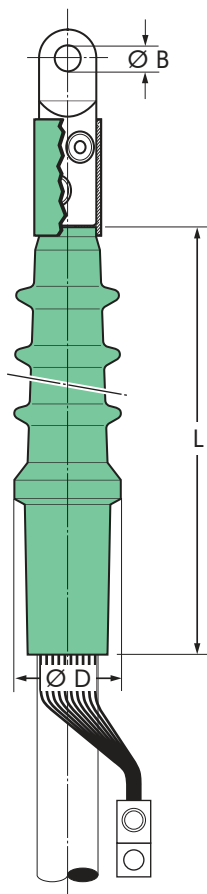
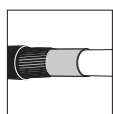

Table 1 - Classification and dimensions

Nominal voltage U ₀ /U (kV)	Conductor cross-section (mm ²)		Dia. over core insulation (mm)		Number of sheds	L (mm)	Dia. D (mm)	Ordering part number
	min.	max.	min.	max.				
6/10	25	95	13.0	20.8	2	150	37	3 x AIN 10 Gr. 1
	120	240	19.4	28.4	2	150	43	3 x AIN 10 Gr. 2
	300	500	27.7	36.4	2	150	60	3 x AIN 10 Gr. 3
	630	800	34.0	45.0	3	225	68	3 x AIN 20 Gr. 4
	1000		39.0	50.0	7	405	98	3 x AIN 36 Gr. 5
	1200		46.0	58.0	7	405	98	3 x AIN 36 Gr. 6
12/20	35	70	18.3	23.5	3	225	47	3 x AIN 20 Gr. 1
	95	240	22.5	33.0	3	225	56	3 x AIN 20 Gr. 2
	300	500	31.0	41.0	3	225	68	3 x AIN 20 Gr. 3
	400	630	34.0	45.0	3	225	68	3 x AIN 20 Gr. 4
	630	800	39.0	50.0	7	405	98	3 x AIN 36 Gr. 5
	1000	1200	46.0	58.0	7	405	98	3 x AIN 36 Gr. 6
18/30	50	70	23.8	28.4	6	300	74	3 x AIN 30 Gr. 1
	95	240	27.1	37.6	6	300	74	3 x AIN 30 Gr. 2
	240	400	31.5	42.8	6	300	81	3 x AIN 30 Gr. 3
	400	630	39.0	50.0	7	405	98	3 x AIN 36 Gr. 5
	630	1200	46.0	58.0	7	405	98	3 x AIN 36 Gr. 6
20.8/36 ²⁾	50	70	23.8	28.4	On request			
	95	120	27.1	32.0	On request			
	150	300	31.5	41.0	7	405	98	3 x AIN 36 Gr. 4
	400	630	39.0	50.0	7	405	98	3 x AIN 36 Gr. 5
	630	1200	46.0	58.0	7	405	98	3 x AIN 36 Gr. 6

²⁾ Since the dimensions for cables at voltage level 20.8/36 (42) kV are not yet standardised, the conductor cross-sections and their assignment of diameters over core insulation given in the table are to be considered approximate values. When ordering accessories, we would like to ask you to indicate the checked diameters over core insulation.

Note: The classification does only apply for polymeric insulated XLPE cables (dimensions acc. to DIN VDE 0276 620) with extruded conductive screen and stranded conductors. Please contact our sales representative, when using other cable types.



For use with copper wire screened cables no earthing device is necessary.

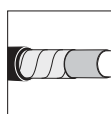

For use with copper tape screened cables.
Order: Kit MT.

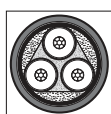

For use with three-core cables please contact our representative.



For use with other cable types please contact our representative.

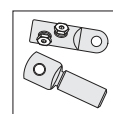

Can be supplied with all common types of cable lugs.

Table 2 - Ordering part number

Conductor sizes (mm ²)	Dia. over core insulation (mm)		Ordering part number (1 Kit = 3 Items)					Termination type (Kit)
			with mechanical connector		with compression connector			
	min.	max.	Ordering part number	Dia. B	Al - rm(V)	Cu - rm(V)	Dia. B	
Nominal voltage U₀/U 6/10 kV								
25 35 50 70 95	13.0	20.8	52175	13	15311061 15311062 15311063 15311064 15311065	15311021 15311022 15311023 15311024 15311025	13 13 13 13 13	AIN 10 Gr. 1
120 150 185 240	19.4	28.4	49494	13	15311066 15311067 15311068 15311069	15311026 15311027 15311028 15311029	13 13 17 17	AIN 10 Gr. 2
300 400 500	27.7	36.4	51262	17	15311070 15311071 15311072	15311030 15311031 15311032	17 17 17	AIN 10 Gr. 3
630 800	34.0	45.0	54919	21	54905 54906	54910 54908	21 21	AIN 20 Gr. 4
1000	39.0	50.0	54920	21	54907	54909	21	AIN 36 Gr. 5
1200	On request							
Nominal voltage U₀/U 12/20 kV								
35 50 70	18.3	23.5	49755	13	15321062 15321063 15321064	15321022 15321023 15321024	13 13 13	AIN 20 Gr. 1
95 120 150 185 240	22.5	33.0	49756	13	15321065 15321066 15321067 15321068 15321069	15321025 15321026 15321027 15321028 15321029	13 13 13 17 17	AIN 20 Gr. 2
300 400 500	31.0	41.0	59085	17	15321070 15321071 15321072	15321030 15321031 15321032	17 17 17	AIN 20 Gr. 3
400 500 630	34.0	45.0	54921	17	54959 54960 59086	54962 54963 54964	17 17 21	AIN 20 Gr. 4
630 800	39.0	50.0	54922	21	54944 54945	54946 54947	21 21	AIN 36 Gr. 5
1000	46.0	58.0	59757	21	57230	57231	21	AIN 36 Gr. 6
1200	On request							
Nominal voltage U₀/U 18/30 kV								
50 70	23.8	28.4	51361	13	44694 45159	44486 45389	13 13	AIN 30 Gr. 1
95 120 150 185 240	27.1	37.6	51363	13	45810 44640 44733 45305 44589	45334 44851 44646 45395 52188	13 13 13 17 17	AIN 30 Gr. 2
240 300 400	31.5	42.8	52186	17	44448 45306 52189	44608 44676 45362	17 17 17	AIN 30 Gr. 3
400 500 630	39.0	50.0	54923	17	54911 54912 54913	54927 54928 54929	17 17 21	AIN 36 Gr. 5
630 800 1000	46.0	58.0	54924	21	54914 54915 54916	54930 54931 54932	21 21 21	AIN 36 Gr. 6
1200	On request							
Nominal voltage U₀/U 20.8/36 kV								
50 70	23.8	28.4	On request					
95 120	27.1	32.0						
150 185 240 300	31.5	41.0	54925	17	54933 54934 54936 54937	54948 54949 54951 54952	13 17 17 17	AIN 36 Gr. 4
400 500 630	39.0	50.0	54926	17	54938 54939 54940	54953 54954 54955	17 17 21	AIN 36 Gr. 5
630 800 1000	46.0	58.0	54862	21	54941 54942 54943	54956 54957 54958	21 21 21	AIN 36 Gr. 6
1200	On request							

AFS

Outdoor slip-on termination

up to 24 kV

Application

AFS terminations are suitable for outdoor installation on polymeric insulated medium voltage cables with extruded easy strip conductive screen or bonded extruded conductive screen. This high-quality silicone termination covers a large range of cross-sections with just two sizes per voltage level. Another

benefit is the quick and easy assembly. The conductor is connected with mechanical cable lugs. Available with additional splitting accessories for three-core cables.

$U_0 / U (U_m)$
6/10 (12) kV
6.35/11 (12) kV
8.7/15 (17.5) kV
12/20 (24) kV
12.7/22 (24) kV

Design

1. Longitudinally sealed mechanical cable lug
2. Integrated silicone tube as sealing element
3. High flexibility silicone rubber housing, ensuring a perfect fit to the cable even during load changes
4. Integrated conductive rubber insert
5. Earthing clamp
6. Earthing cable lug
7. Heat-shrinkable tube
8. Heat-shrinkable break-out

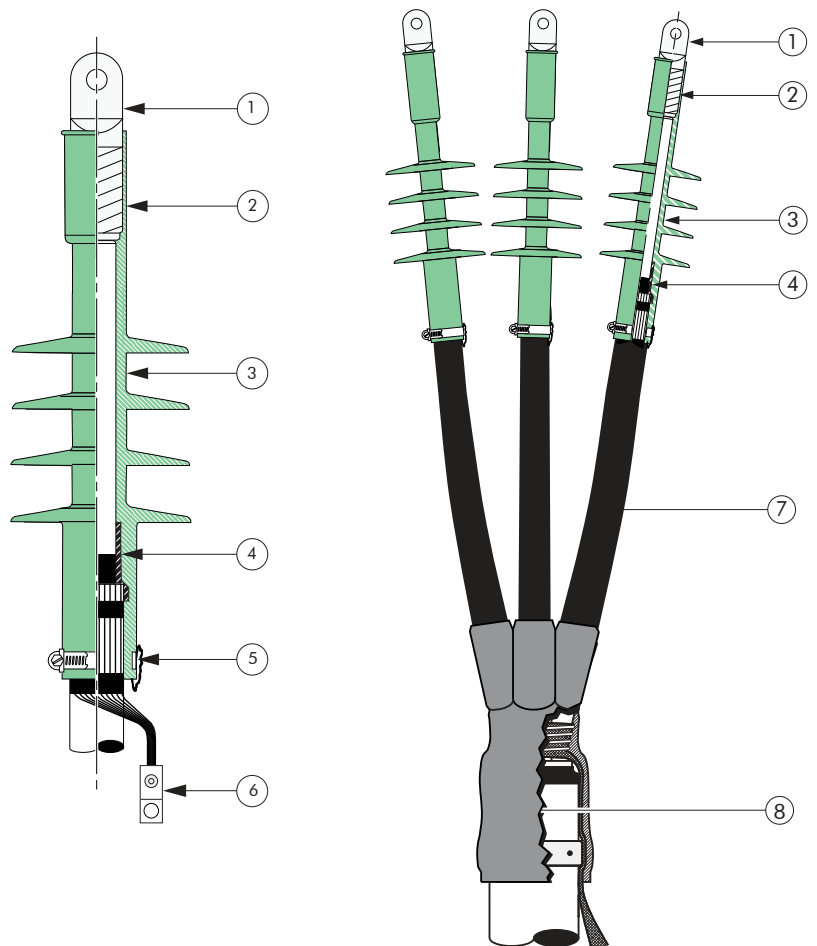

Specifications and standards

This termination meets the requirements of CENELEC HD 629.1.

Termination type	Nominal voltage U_0 / U (kV)	Conductor cross-section (mm ²) ¹⁾	
		min.	max.
AFS 20	6/10	70	300
AFS 20	12/20	25	300

¹⁾ Other cross-sections are available on request.

Kit contents

- 3 termination housings
- 3 mechanical cable lugs for the conductor
- 3 mechanical screen wire cable lugs
- Installation instructions
- Silicone grease
- Assembly incidentals

Ordering instructions

Indicate the part number when ordering (see table).

Order example:

1 AFS 20 kit for 12/20 kV, for 70-240 mm² with mechanical cable lug (palm hole diameter 13 mm).

Order according to table 2:

1 kit – AFS 20 size 2 with part number 501520.

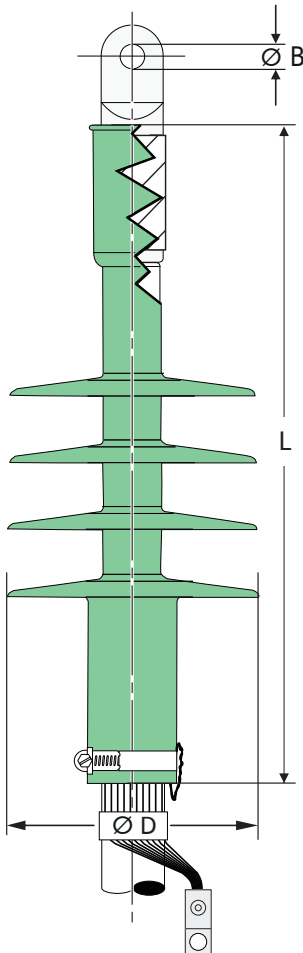

Table 1 - Classification and dimensions

Nominal voltage U_0/U (kV)	Conductor cross-section (mm ²)		Dia. over core insulation (mm)		L (mm)	Dia. D ²⁾ (mm)	Termination type
	min.	max.	min.	max.			
6/10	70	95	17.0	27.0	295	~100	AFS 20-1
12/20	25	95					
6/10	150	240	20.9	35.0	325		AFS 20-2
12/20	70	240					
	150	300					
	70	95					
	95	150					
	120	240					
	150	300					

Table 2 - Ordering part number

Conductor cross-section (mm ²)	Dia. over core insulation (mm)		Ordering part number (1 Kit = 3 Items)				Termination type (Kit)		
			with mechanical cable lug						
			Dia. B 13 mm		Dia. B 17 mm				
Nominal voltage U_0/U (U_m) 6/10 (12) kV									
70	17.0	27.0	501513	501514 ³⁾	501523	501524 ³⁾	AFS 20-1		
95									
120									
150	20.9	35.0	501515	501517	501525	501527	AFS 20-2		
185									
240									
300									
Nominal voltage U_0/U (U_m) 12/20 (24) kV									
25	17.0	27.0	501518	501519	501621	501622	AFS 20-1		
50									
70									
95									
120									
70	20.9	35.0	501520	501521	501522	501623	501624	501625	AFS 20-2
95									
120									
150									
185									
240									
300									

²⁾ Cross-section 25 mm² according to DIN VDE 0276-620 unavailable.

³⁾ The indicated diameter is a mould dimension. Depending on the conductor cross-section used, a deviation of up to +5 mm is possible.

Note: The classification does only apply for polymeric insulated XLPE cables (dimensions acc. to DIN VDE 0276 620) with extruded conductive screen and stranded conductors.

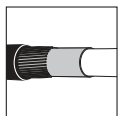

For use with copper wire screened cables no earthing device is necessary.

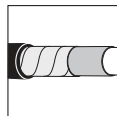

For use with copper tape screened cables.
Order : KIT MT.

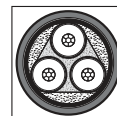

For use with three-core cables please contact our representative.



For use with other cable types please contact our representative.

AFN

Outdoor slip-on termination

up to 42 kV

Application

AFN 10, AFN 20, AFN 30 and AFN 36 termination are suitable for outdoor installation on polymeric insulated medium voltage cables with extruded easy strip conductive screen or bonded extruded conductive screen. With this highquality silicone termination, the entire range of cross-sections is covered with

just a few sizes per voltage level. Another benefit given by using the AFN termination is the quick and easy assembly. The conductor can be alternatively connected with mechanical or compression cable lugs. The termination is available with additional splitting accessories for three-core, copper wire screened or copper tape screened and armored cables.

$U_0 / U (U_m)$
6/10 (12) kV
6.35/11 (12) kV
8.7/15 (17.5) kV
12/20 (24) kV
12.7/22 (24) kV
18/30 (36) kV
19/33 (36) kV
20.8/36 (42) kV

Design

1. Longitudinally sealed mechanical or compression cable lug
2. Silicone tube or cap as additional sealing at the transition of cable lug to the termination housing when using mechanical cable lugs
3. High flexibility silicone rubber housing, ensuring a perfect fit to the cable even during load changes
4. Integrated conductive rubber insert
5. Water sealing mastic
6. Earthing clamp
7. Earth cable lug
8. Heat-shrinkable tube
9. Heat-shrinkable break-out

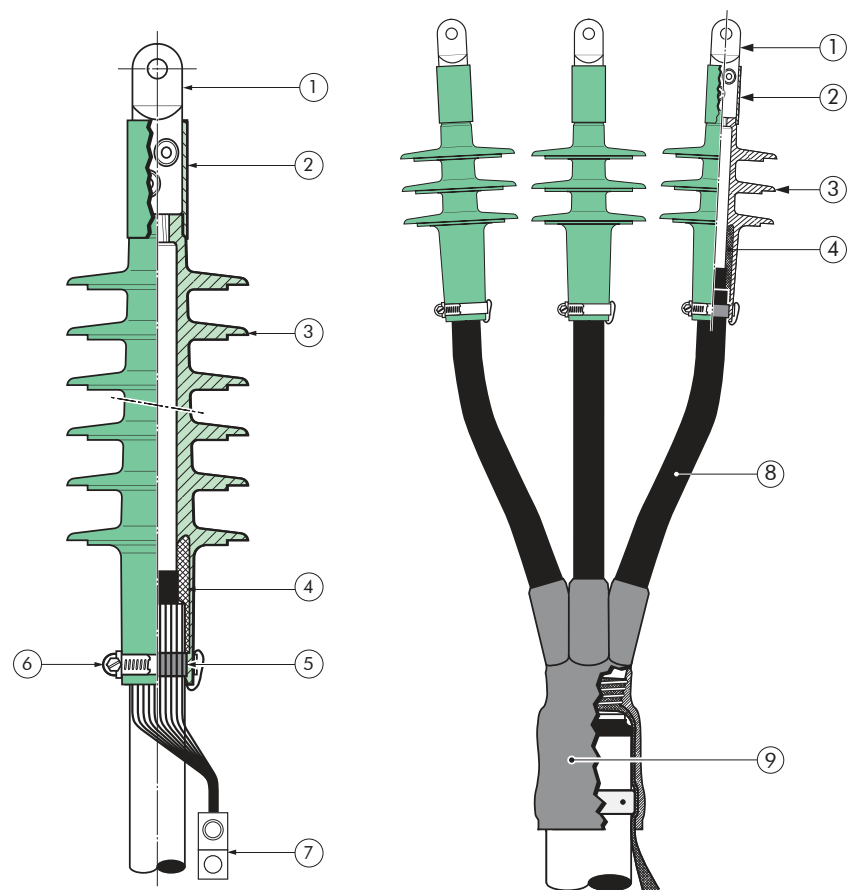

Specifications and standards

Meets the requirements of CENELEC HD 629.1

Termination type	Nominal voltage U_0 / U (kV)	Conductor cross-section (mm ²) ¹⁾	
		min.	max.
AFN 10	6/10	25	1000 (1200)
AFN 20	12/20	35	1000 (1200)
AFN 30	18/30	50	1000 (1200)
AFN 36	20.8/36	50	1000 (1200)

¹⁾ Other cross-sections are available on request.

Kit contents

- 3 termination housings
- 3 mechanical or compression cable lugs for the conductor
- 3 mechanical or compression screen wire cable lugs
- Installation instructions
- Silicone grease
- Assembly incidentals

Ordering instructions

Indicate the part number when ordering (see table).

Order example:

1 AFN 20 kit for 12/20 kV, for 95-240 mm² with mechanical cable lug (palm hole diameter 13 mm).
Order according to table 2:
1 kit – AFN 20 size 2 with part number 48793.

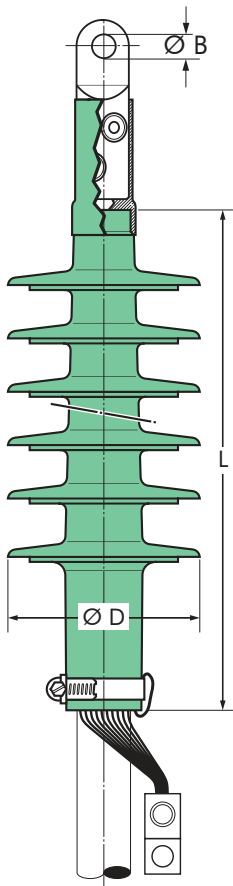
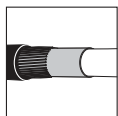

Table 1 - Classification and dimensions

Nominal voltage U ₀ /U (kV)	Conductor cross-section (mm ²)		Dia. over core insulation (mm)		Number of sheds	L (mm)	Dia. D (mm)	Creepage distance (mm)	Ordering part number
	min.	max.	min.	max.					
6/10	25	95	12.7	20.8	3	210	90	369	3 x AFN 10 Gr.1
	120	240	19.2	28.4	3	210	96	365	3 x AFN 10 Gr.2
	300	500	27.4	36.4	3	210	105	360	3 x AFN 10 Gr.3
	630	800	34.0	45.0	4	240	118	462	3 x AFN 20 Gr.4
	1000		39.0	50.0	7	330	127	680	3 x AFN 30 Gr.4
	1200		46.0	58.0	7	405	127	755	3 x AFN 36 Gr.6
12/20	35	70	18.3	23.5	4	240	100	480	3 x AFN 20 Gr.1
	95	240	22.5	33.0	4	240	112	499	3 x AFN 20 Gr.2
	300	500	31.0	41.0	4	240	118	462	3 x AFN 20 Gr.3
	400	630	34.0	45.0	4	240	118	462	3 x AFN 20 Gr.4
	630	800	39.0	50.0	7	330	127	680	3 x AFN 30 Gr.4
	1000	1200	46.0	58.0	7	405	127	755	3 x AFN 36 Gr.6
18/30	50	70	23.8	28.4	6	300	115	695	3 x AFN 30 Gr.1
	95	240	27.1	37.6	6	300	115	694	3 x AFN 30 Gr.2
	240	400	31.5	42.8	6	300	127	718	3 x AFN 30 Gr.3
	400	630	39.0	50.0	7	330	127	680	3 x AFN 30 Gr.4
	630	1200	46.0	58.0	7	405	127	755	3 x AFN 36 Gr.6
20.8/36 ²⁾	50	70	23.8	28.4	6	300	115	695	3 x AFN 30 Gr.1
	95	240	27.1	37.6	6	300	115	694	3 x AFN 30 Gr.2
	240	400	31.5	42.8	6	300	127	718	3 x AFN 30 Gr.3
	400	630	39.0	50.0	7	330	127	680	3 x AFN 30 Gr.4
	630	1200	46.0	58.0	7	405	127	755	3 x AFN 36 Gr.6

²⁾ Since the dimensions for cables at voltage level 20.8/36 (42) kV are not yet standardised, the conductor cross-sections and their assignment of diameters over core insulation given in the table are to be considered approximate values. When ordering accessories, we would like to ask you to indicate the checked diameters over core insulation.

Note: The classification does only apply for polymeric insulated XLPE cables (dimensions acc. to DIN VDE 0276 620) with extruded conductive screen and stranded conductors. Please contact our sales representative, when using other cable types.



For use with copper wire screened cables no earthing device is necessary.

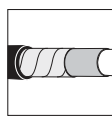

For use with copper tape screened cables. Order: Kit MT.

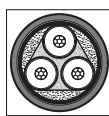

For use with three-core cables please contact our representative.



For use with other cable types please contact our representative.

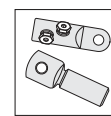

Can be supplied with all common types of cable lugs.

Table 2 - Ordering part number

Conductor cross-section (mm ²)	Dia. over core insulation (mm)		Ordering part number (1 Kit = 3 Items)					Termination type (Kit)
			with mechanical connector		with compression connector			
	min.	max.	Ordering part number	Dia. B	Al - rm(V)	Cu - rm(V)	Dia. B	
Nominal voltage U₀/U 6/10 kV								
25	12.7	20.8	52190	13	52196	52197	13	AFN 10 Gr. 1
35					52198	48330	13	
50					52199	49750	13	
70					52200	49877	13	
95					52201	48939	13	
120	19.2	28.4	52191	13	52202	47989	13	AFN 10 Gr. 2
150					45599	45730	13	
185					52203	52204	17	
240					45384	45090	17	
300	27.4	36.4	52194	17	52205	47969	17	AFN 10 Gr. 3
400					52206	45733	17	
500					48084	44691	17	
630	34.0	45.0	54863	21	54879	54864	21	AFN 20 Gr. 4
800					57576	54865	21	
1000	39.0	50.0	57242	21	57243	57244	21	AFN 30 Gr. 4
1200	On request							
Nominal voltage U₀/U 12/20 kV								
35	18.3	23.5	51355	13	49628	45481	13	AFN 20 Gr. 1
50					45315	45365	13	
70					49624	45521	13	
95	22.5	33.0	48793	13	44564	45109	13	AFN 20 Gr. 2
120					49625	45749	13	
150					44189	44668	13	
185					49626	44643	17	
240					44340	44487	17	
300	31.0	41.0	59080	17	45477	45403	17	AFN 20 Gr. 3
400					45598	45164	17	
500					49630	44563	17	
400	34.0	45.0	54965	17	54966	59081	17	AFN 20 Gr. 4
500					54866	59082	17	
630					59084	59083	21	
630	39.0	50.0	57245	21	57246	57248	21	AFN 30 Gr. 4
800					57247	57249	21	
1000	46.0	58.0	59758	21	57567	57568	21	AFN 36 Gr. 6
1200	On request							
Nominal voltage U₀/U 18/30 kV								
50	23.8	28.4	51367	13	49635	45140	13	AFN 30 Gr. 1
70					49637	49636	13	
95	27.1	37.6	51369	13	48677	49638	13	AFN 30 Gr. 2
120					49640	49639	13	
150					49641	48085	13	
185					48002	45396	17	
240					44670	44669	17	
240	31.5	42.8	52213	17	52220	52219	17	AFN 30 Gr. 3
300					49642	44791	17	
400					45235	48108	17	
400	39.0	50.0	57273	17	57274	57275	17	AFN 30 Gr. 4
500					48577	48580	17	
630					48578	48581	21	
630	46.0	58.0	54857	21	54917	54875	21	AFN 36 Gr. 6
800					54873	54876	21	
1000					54874	54877	21	
1200	On request							
Nominal voltage U₀/U 20.3/36 kV								
50	23.8	28.4	57250	13	57253	57263	13	AFN 30 Gr. 1
70					57254	57264	13	
95	27.1	37.6	57251	13	57255	57265	13	AFN 30 Gr. 2
120					57256	57266	13	
150					57257	57267	13	
185					57258	57268	17	
240					57259	57269	17	
240	31.5	42.8	57252	17	57260	57270	17	AFN 30 Gr. 3
300					57261	57271	17	
400					57262	57272	17	
400	39.0	50.0	57276	17	57277	57280	17	AFN 30 Gr. 4
500					57278	57281	17	
630					57279	57282	21	
630	46.0	58.0	54860	21	54886	54897	21	AFN 36 Gr. 6
800					54887	54898	21	
1000					54888	54899	21	
1200	On request							

15-01-2019





**READY-TO-INSTALL,
PRE-ASSEMBLED CABLES**
up to 42 kV

READY-TO-INSTALL, PRE-ASSEMBLED CABLES

Interface A to F connectors and terminations
up to 42 kV

Application

Pre-assembled cables are polymeric insulated medium voltage cables, equipped with connectors and terminations. They can be used for connecting transformers and switchgears. We manufacture the pre-assembled cables specifically customized in terms of cable length and type

of accessories. The cables and flexible cables, primarily checked by us, are assembled with different conductor cross-sections and accessories, depending on customer's application.

$U_0 / U (U_m)$
6/10 (12) kV
6.35/11 (12) kV
8.7/15 (17.5) kV
12/20 (24) kV
12.7/22 (24) kV
18/30 (36) kV
19/33 (36) kV
20.8/36 (42) kV

Flexible cables

Pre-assembled flexible cables, such as NTMCGCWÖU, are used in stations with little space, where the bending radii cannot be met with XLPE-insulated cables.

Due to their design

- Fine-wire, tin-plated copper conductor
- Ethylene-propylene rubber (EPR) insulation
- Fine-wire shield
- Polychloroprene (flame- and oil-resistant) outer sheath, these flexible cables can be laid with minimum bending radii of 5 times the outside diameter.

In terms of their current-carrying capacity in service and in the case of short-circuit current, EPR-insulated cables are almost equivalent to XLPE-insulated cables.

Cables

Pre-assembled cables type N(A)2XS(2)Y are used where the space conditions inside equipment allow the minimum cable bending radius of 15 times its outside diameter.

Dimensioning basis

When dimensioning the preassembled cable length, we take the center points of both cable accessories as the basis. When indicating the length of the shield wire, please also specify whether the shield wire should be lead out on one or both sides.

Accessory A

See table for accessory selection.

Accessory B

See table for accessory selection.

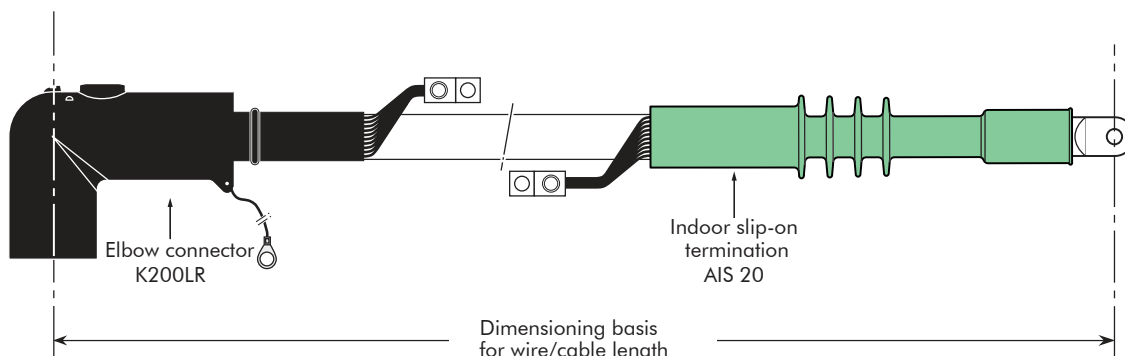

Example request

Please fill in what is applicable.

	U ₀ /U (kV) 6/10			U ₀ /U (kV) 12/20			U ₀ /U (kV) 18/30			U ₀ /U (kV) 20.8/36			Length of shield wire ¹⁾
	L 1	L 2	L 3	L 1	L 2	L 3	L 1	L 2	L 3	L 1	L 2	L 3	
Conductor/ cable type													
Conductor/ cable length													
Accessory A													
Accessory B													
PD sample test	yes / no			yes / no			yes / no			yes / no			
AC withstand test	yes / no			yes / no			yes / no			yes / no			

¹⁾ If not indicated, we assume a shield wire length of 500 mm for both cable ends.

Accessory selection

We also assemble accessories not listed here.

Type	Design	Interface	Material	Assembly technique
(K)200LR/G	Elbow connector	A	EPDM	Slip-on technology
(K)200SR/G	Straight connector	A	EPDM	Slip-on technology
(K)158LR(/G)	Elbow connector	A	EPDM	Slip-on technology
(K)152SR(/G)	Straight connector	A	EPDM	Slip-on technology
(K)(M)400LR/G	Elbow connector	B	EPDM	Slip-on technology
(K)(M)430TB/G	Compact tee connector	C	EPDM	Slip-on technology
(K)(M)(P)480TB/G	Compact tee connector	C	EPDM	Slip-on technology
(K)(M)(P)800PB/G	Coupling connector	C	EPDM	Slip-on technology
(K)(M)(P)484TB/G	Compact tee connector	C	EPDM	Slip-on technology
(K)(M)(P)804PB/G	Coupling connector	C	EPDM	Slip-on technology
(K)(M)(P)489TB/G	Compact tee connector	C	EPDM	Slip-on technology
(K)(M)(P)809PB/G	Coupling connector	C	EPDM	Slip-on technology
(K)676LRA/G	Separable tee connector	D	EPDM	Slip-on technology
784TB/G	Separable tee connector	E	EPDM	Slip-on technology
(K)(M)(P)944TB/G	Compact tee connector	F	EPDM	Slip-on technology
AIS 20	Indoor termination	-	Silikon	Slip-on technology
AIP 20	Indoor termination	-	Silikon	Slip-on technology
AIN 10	Indoor termination	-	Silikon	Slip-on technology
AIN 20	Indoor termination	-	Silikon	Slip-on technology
AIN 30	Indoor termination	-	Silikon	Slip-on technology
AIN 36	Indoor termination	-	Silikon	Slip-on technology
AFS 20	Outdoor termination	-	Silikon	Slip-on technology
AFN 10	Outdoor termination	-	Silikon	Slip-on technology
AFN 20	Outdoor termination	-	Silikon	Slip-on technology
AFN 30	Outdoor termination	-	Silikon	Slip-on technology
AFN 36	Outdoor termination	-	Silikon	Slip-on technology



A worker in an orange safety suit and yellow helmet is kneeling in a trench, working with several large red and black cables. The worker is using a tool to handle the cables. The trench is dug into the ground, and there are other cables and equipment visible in the background. The scene is outdoors, with a dirt embankment on the right side.

STRAIGHT JOINTS
TRANSITION JOINTS
up to 42 kV

GTS1

Single-core straight joint

Heat-shrink technology
up to 42 kV

Application

The heat-shrinkable straight joint type GTS1 is suitable for jointing polymeric insulated medium voltage cables with extruded easy strip conductive screen or bonded extruded conductive screen. With regards to the mechanical conductor connector, supplied in the joint kit, jointing of cables

with different conductor sizes or conductor materials becomes fast and easy.

$U_0 / U (U_m)$
6/10 (12) kV
6.35/11 (12) kV
8.7/15 (17.5) kV
12/20 (24) kV
12.7/22 (24) kV
18/30 (36) kV
19/33 (36) kV
20.8/36 (42) kV

Design

1. Dual wall tube
2. Stress control tube
3. Stress control mastic
4. Overall protection tube
5. Sealing mastic
6. Screen continuity (copper mesh)
7. Conductor connector
8. Screen wire connector (optionally roll springs)
9. Sealing mastic
10. Insulation sleeve (only for cross-sections $> 630 \text{ mm}^2$, 36GTS1 and 42GTS1)

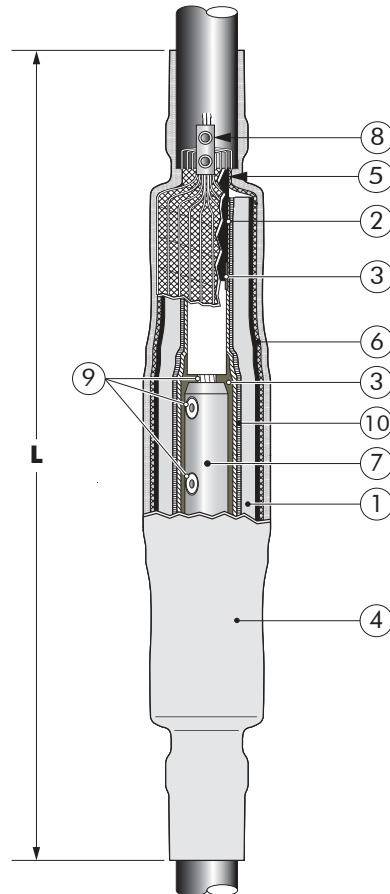

Specifications and standards

The heat-shrinkable straight joint GTS1 meets the requirements of CENELEC HD 629.1.

Joint type	Nominal voltage U_0 / U (kV)	Conductor cross-section (mm^2) ¹⁾		Length L (mm)
		min.	max.	
17GTS1	6/10	25	1000	750 - 1000
24GTS1	12/20	35	1000 (1200)	750 - 1000
36GTS1	18/30	50	1000 (1200)	1000
42GTS1	20.8/36	50	1000	1000 - 1200

¹⁾ Other cross-sections on request.

Kit contents

The complete GTS1 joint kit comprises the following components:

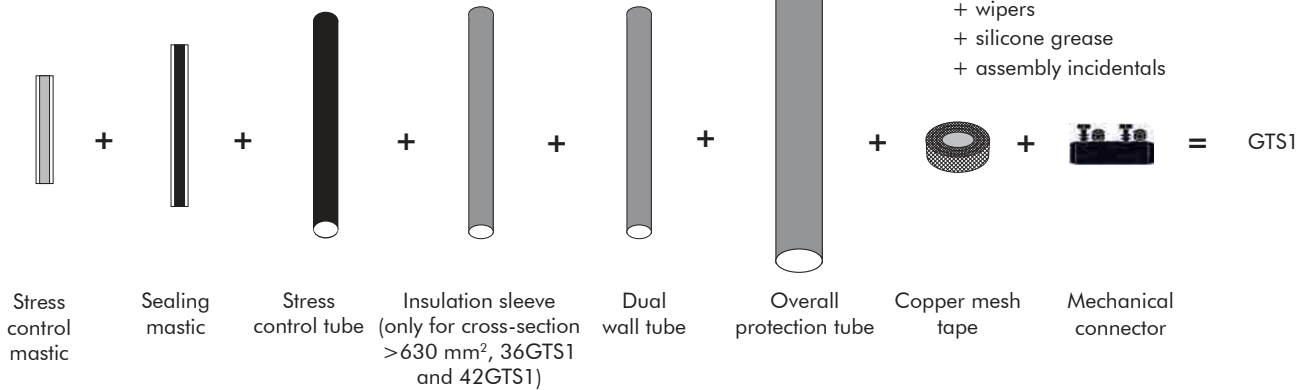

Ordering instructions

Select the straight joint type corresponding to both system voltage and conductor cross-section.

Order example:

Heat-shrinkable straight joint type 24GTS1.240 for XLPE cable 12/20 kV 50-240 mm² conductor cross-section.
Order number: 52612

Note: The classification does only apply for polymeric insulated XLPE cables (dimensions acc. to DIN VDE 0276 620) with extruded conductive screen. Please contact our representative, when using other cable types.

Joint type	Nominal voltage U ₀ /U (kV)	Conductor cross-section (mm ²)	Conductor cross-section (mm ²)												
			25	35	50	70	95	120	150	185	240	300	400	500	630
17GTS1.95	6/10	25	95	52606											
17GTS1.240	6/10	95	240	52607											
17GTS1.400	6/10	240	400	52608											
17GTS1.630	6/10	400	630	52609											
17GTS1.1000	6/10	800	1000	53504											
24GTS1.50	12/20	35	50	52610											
24GTS1.240	12/20	50	150 ²⁾	52611 ²⁾											
24GTS1.240	12/20	50	240	52612											
24GTS1.240	12/20	95	240	49758											
24GTS1.300	12/20	120	300	58023											
24GTS1.400	12/20	185	400	52613											
24GTS1.630	12/20	400	630	52615											
24GTS1.1000	12/20	630	1000	53661											
36GTS1.95	18/30	50	95	52616											
36GTS1.240	18/30	95	240	52618											
36GTS1.500	18/30	185	400	52619											
36GTS1.800	18/30	400	630	52620											
36GTS1.1000	18/30	630	1000	59209											
42GTS1.95	20.8/36	50	95	57225											
42GTS1.150	20.8/36	50	150 ²⁾	57226 ²⁾											
42GTS1.240	20.8/36	95	240	59859											
42GTS1.400	20.8/36	185	400	57227											
42GTS1.630	20.8/36	400	630	57228											
42GTS1.1000	20.8/36	630	1000	57229											

²⁾ Applicable for aluminum conductors up to 150 mm² and copper conductors up to 120 mm².

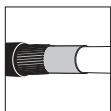

For use with copper wire screened cables no further earthing device is necessary.

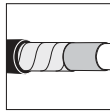

For use with copper tape screened cables, endorse "A" to the part number. (e.g. 24GTS1.240A)



For use with other cables types please contact our representative.



For use with three-core cables see GTS3.

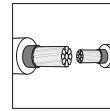

Joining cables of different sizes possible.

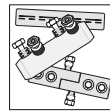

Can be used with all common types of conductor connectors.

CSJ

Single-core straight joint

Cold-shrink technology
up to 36 kV

Application

The cold-shrinkable straight joint type CSJ is suitable for jointing polymeric insulated medium voltage cables with extruded easy strip conductive screen or bonded extruded conductive screen. With regards to the mechanical conductor connector, supplied in the joint kit, jointing of cables with

different conductor sizes or conductor materials becomes fast and easy.

$U_0 / U (U_m)$
6/10 (12) kV
6.35/11 (12) kV
8.7/15 (17.5) kV
12/20 (24) kV
18/30 (36) kV
19/33 (36) kV

Design

1. Extruded triple layer EPDM rubber body
2. Two layer plate with a semi-conductive and a field control mastic layer
3. Overall protective EPDM cover
4. Field control mastic
5. Water sealing mastic
6. Copper braid
7. Self-adhesive copper tape
8. Traceability tag
9. Mechanical conductor connector

Technical characteristics

All joint bodies are tested for AC withstand prior to leaving the factory.

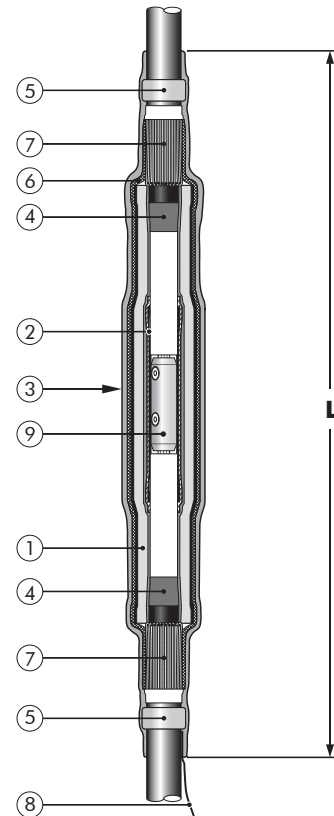

Specifications and standards

The cold-shrinkable straight joint CSJ meets the requirements of CENELEC HD 629.1.

Joint type	Nominal voltage U_0 / U (kV)	Conductor cross-section (mm ²)		Dia. over core insulation (mm)		Max. dia. over outer sheath (mm)	L (mm)
		min.	max.	min.	max.		
24CSJ-2 Gr. 1	6/10	18	23	95	150	46	ca. 750
24CSJ-2 Gr. 2	6/10	23	33	150	240/(300) ¹⁾	46	ca. 750
24CSJ-2 Gr. 1	12/20	18	23	35	70	46	ca. 750
24CSJ-2 Gr. 2	12/20	23	33	95	240/(300) ¹⁾	46	ca. 750
24CSJ - 3	12/20	30	45	240	630	57	ca. 850
36CSJ-2	18/30	23	36	50	240	48	ca. 750
36CSJ-3	18/30	30	50	185	630	57	ca. 850

¹⁾ Conductor sizes in brackets available with compression joint.

Kit contents

The complete joint kit CSJ comprises the following components:

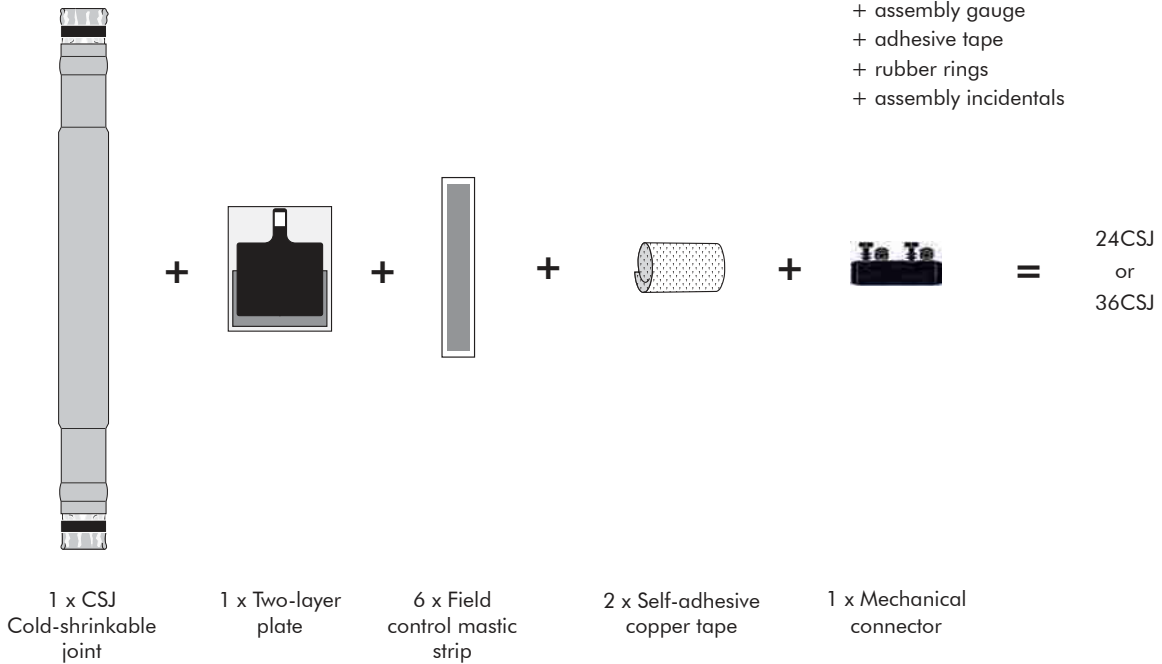

Ordering instructions

Select the straight joint type corresponding to the cable type and dia. over core insulation.

Order example:

Single-core straight joint
Nominal voltage 12/20 kV,
Conductor cross-section 95-240 mm²
Dia. over core insulation 23-33 mm²
Order number: 48136

Joint type	Nominal voltage U ₀ /U (kV)	Conductor cross-section (mm ²)													Dia. over core insulation (mm)	Max. dia. over outer sheath (mm)		
		35	50	70	95	120	150	185	240	300	400	500	630	800			1000	
24CSJ-2 Gr. 1	6/10				53752 ²⁾												18-23	46
24CSJ-2 Gr. 2	6/10						59088										23-33	46
24CSJ-2 Gr. 1	12/20	59087															18-23	46
24CSJ-2 Gr. 2	12/20				48136 ³⁾												23-33	46
24CSJ-3	12/20									52650 ³⁾							30-54	57
24CSJ-3	12/20										51800 ³⁾						30-54	57
36CSJ-2 Gr. 2	18/30		53738 ²⁾														23-36	48
36CSJ-2 Gr. 2	18/30				53737												23-36	48
36CSJ-3	18/30							57216									30-50	57
36CSJ-3	18/30										57217 ³⁾						30-50	57

²⁾ Applicable for aluminum conductors up to 150 mm² and copper conductors up to 120 mm².

³⁾ Please consider the maximum outer cable diameter.

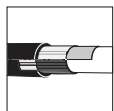

For use with Alupe cables please contact our representative



For use with other cable types please contact our representative



For use with three-core cables see TT-24CSJ.

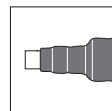

Can be supplied as stop joint. Please contact our representative

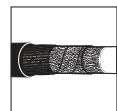

For use with fabric tape (graphite) screened cables order additional semi-conductive tape.

24CSJA-S

Compact single-core straight joint

Cold-shrink technology
up to 24 kV

Application

The cold-shrinkable straight joint 24CSJA-S is used for jointing medium voltage cables with a copper wire screen and extruded conductive screen.

This product can be installed where installation space is limited. With regards to the mechanical conductor connector, jointing of cables

with different conductor sizes or conductor materials becomes fast and easy.

$U_0 / U (U_m)$
6/10 (12) kV
6.35/11 (12) kV
8.7/15 (17.5) kV
12/20 (24) kV
12.7/22 (24) kV

Design

1. Extruded triple layer EPDM rubber body
2. Two layer plate with a semi-conductive and a field control mastic layer
3. Overall protective EPDM cover
4. Field control mastic
5. Water sealing mastic
6. Copper braid
7. Self-adhesive copper tape
8. Traceability tag
9. Mechanical conductor connector

Technical characteristics

All joint bodies are tested for AC withstand prior to leaving the factory.

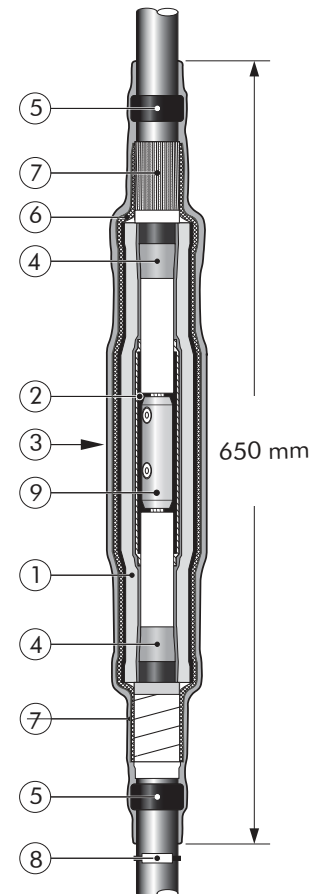

Specifications and standards

The cold-shrinkable 24CSJA-S joint meets the requirements of CENELEC HD 629.1.

Joint type	Nominal voltage U_0 / U (kV)	Conductor cross-section (mm ²)		Dia. over core insulation (mm)		Max. dia. over outer sheath (mm)
		min.	max.	min.	max.	
24CSJA-S/M95-300	6/10	185	300	23	38	52
24CSJA-S/M95-300	12/20	95	300	23	38	52

Kit contents

The complete joint kit 24CSJA-S comprises the following components:

The kit also comprises:
 + installation instructions
 + silicone grease
 + wipers
 + installation hook
 + assembly gauge
 + assembly incidentals
 + conductive tape

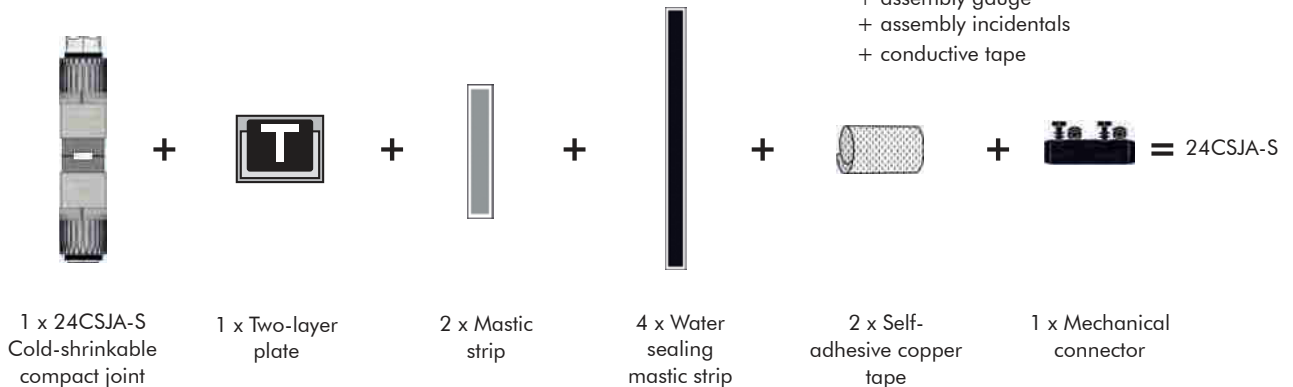

Highlights

- Compact dimensions allow the easy and space-saving installation.
- Low number of components due to pre-assembled extruded triple layer EPDM joint body on support tube.
- Fast and easy installation by pulling out the support tube in a single movement.
- All joint bodies are electrically tested prior to leaving the factory.
- Cold-shrinkable joints 24CSJA-S exceed international performance standards including CENELEC HD 629.1 and IEC 60502-4.
- Mechanical connectors and cable lugs supplied in the joint kit are tested and certified acc. to IEC 61238-1-A.
- No special tools or flame required.
- Advanced screen connection system.
- Cold-shrinkable joints can be energized immediately after installation.



Joint type	Nominal voltage U_0/U (kV)	Conductor cross-section (mm ²)						Dia. over core insulation (mm)	Max. dia. over outer sheath (mm)
		95	120	150	185	240	300		
24CSJA-S/M95-300	6/10	501451						23-38	52
24CSJA-S/M95-300	12/20							23-38	52

Ordering instructions

Select the straight joint type corresponding to the cable type and dia. over core insulation.

Order example

Compact single-core straight joint,
 Nominal voltage 12/20 kV,
 Conductor cross-section 95-300 mm²
 Dia. over core insulation 23-38 mm
 Order number: 501451

Note: The classification does only apply for polymeric insulated XLPE cables (dimensions acc. to DIN VDE 0276 620) with extruded conductive screen and stranded conductors. Please contact our representative, when using other cable types.

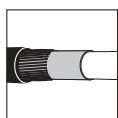

For use with copper wire screened cables no further earthing device is necessary.

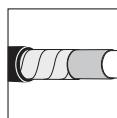

For use with copper tape screened cables, endorse "A" to the part number.

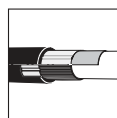

For use with Alupe cables please contact our representative

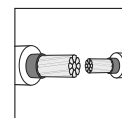

Joining cables of different sizes possible.



For use with other cable types please contact our representative

GTM3.1

Three-core transition joint

Heat-shrink technology
up to 42 kV

Application

Heat-shrinkable transition joint for jointing three-core paper cables to three single-core polymeric cables. For use with belted or screened cables with a common or individual lead sheath. This transition joint is fully screened, submersible and suitable to be directly buried.

$U_0 / U (U_m)$
6/10 (12) kV
6.35/11 (12) kV
8.7/15 (17.5) kV
12/20 (24) kV
12.7/22 (24) kV
18/30 (36) kV
19/33 (36) kV
20.8/36 (42) kV

Design

1. Dual wall tube
2. Stress control tube
3. Protection tube
4. Field control mastic
5. Sealing mastic
6. Screen wire connector
7. Mechanical conductor connector
8. Semi-conductive heat-shrinkable breakout (17GTM3.1)
9. Semi-conductive tube (17GTM3.1)
10. Barrier tube
11. Heat-shrinkable breakout

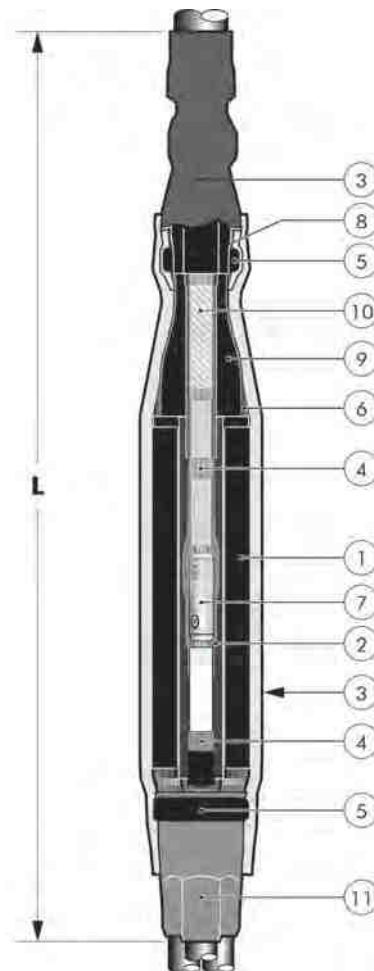

Specifications and standards

The heat-shrinkable transition joint GTM3.1 meets the requirements of CENELEC HD 629.2.

Joint type	Nominal voltage U_0 / U (kV)	Conductor cross-section (mm ²)		L (mm)
		min.	max.	
17GTM3.1	6/10	25	400	~1200
24GTM3.1	12/20	35	400	~1200
42GTM3.1 ¹⁾	18/30 + 20.8/36	50	400	~1800

¹⁾ The joint type is suitable for voltage levels 18/30 (36) kV and 20.8/36 (42) kV, type tested for 20.8/36 (42) kV.

Kit contents

The complete joint kit GTM3.1 comprises the following components:

The kit also comprises:
 + installation instructions
 + mechanical conductor connector
 + mechanical screen wire connector
 + roll springs
 + assembly incidentals
 + copper mesh tape

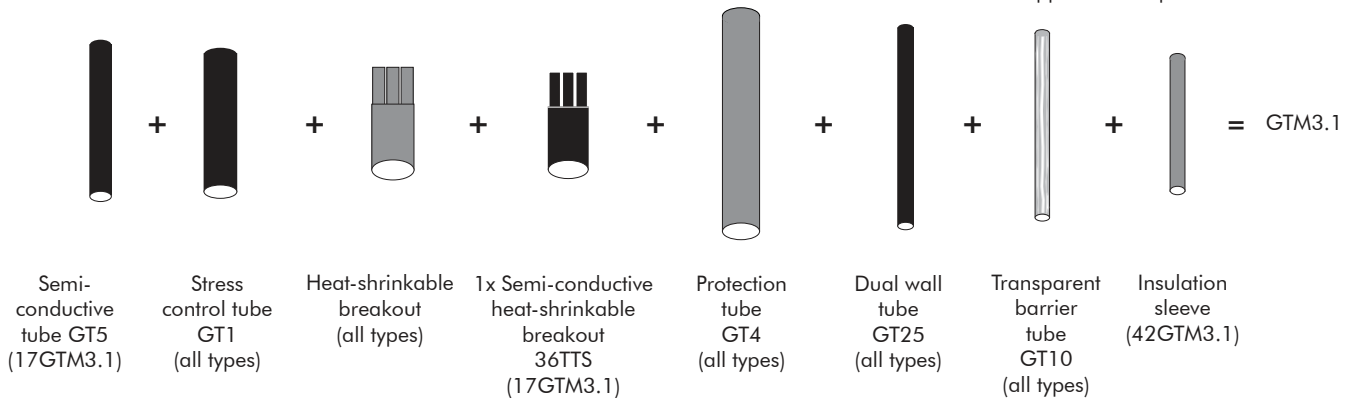

Ordering instructions

Please indicate the part number when ordering (see table). Select the order designation of the transition joint according to the cable type used and the diameter over core insulation. Joint types for connecting different conductor cross-sections available on request. Transition joints for 12/20 (24) kV and 18/30 (36) kV H-cables to XLPE-insulated single-core cables available on request.

Order example:

For paper-insulated belted cable with 6/10 kV, 3 x 150 mm² to XLPE-insulated single-core cable with 6/10 kV, 120 mm². Order according to the table: 17GTM3.1.240 part number 59854.

Joint type	Nominal voltage U ₀ /U (kV)	Conductor cross-section (mm ²)		Ordering part number
		min.	max.	
17GTM3.1.95	6/10	25	95	57288 ²⁾
17GTM3.1.240	6/10	95	240	59854 ²⁾
17GTM3.1.300	6/10	120	300	58844 ²⁾
17GTM3.1.400	6/10	240	400	57289 ²⁾
24GTM3.1.150	12/20	35	50	57290 ³⁾
24GTM3.1.240	12/20	70	240	57291 ³⁾
24GTM3.1.300	12/20	120	300	58209 ³⁾
24GTM3.1.400	12/20	185	400	57292 ³⁾
42GTM3.1.95 ¹⁾	18/30 + 20,8/36	50	95	57293 ³⁾
42GTM3.1.150 ¹⁾	18/30 + 20,8/36	95	150	57294 ³⁾
42GTM3.1.240 ¹⁾	18/30 + 20,8/36	150	240	57295 ³⁾
42GTM3.1.300 ¹⁾	18/30 + 20,8/36	120	300	58845 ³⁾
42GTM3.1.400 ¹⁾	18/30 + 20,8/36	240	400	57296 ³⁾

¹⁾ The joint type is suitable for voltage levels 18/30 (36) kV and 20.8/36 (42) kV, type tested for 20.8/36 (42) kV.

²⁾ Transition joints for paper-insulated belted cables to XLPE-insulated single-core cables.

³⁾ Transition joints for three-core single lead sheath cable to XLPE-insulated single-core cables.

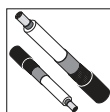

When jointing cables of different sizes please contact our representative.



For use with other cable types please contact our representative.

SVMS/SVMS-P In-line joint including mechanical connectors

without/with parking position, design acc. to DIN V 47640
Heat-shrink technology

Application

The heat-shrinkable in-line joint SVMS/SVMS-P is used for jointing four- and five-core polymeric insulated cables with concentric conductor and PVC or XLPE insulation as well as PVC or PE outer sheaths. The joints are designed for use of mechanical connectors accommodating copper or

aluminum conductors. This heat-shrinkable joints offer a sealed indoor or outdoor application.

$U_0 / U (U_m)$
0.6/1 (1.2) kV

Design

The inner and outer heat-shrinkable tubing is thick-walled and co-extruded with adhesive quality. The joint design and tube dimensions are according to DIN V 47640.

Technical characteristics

For application SVMS-P including a parking position of mechanical contacts on conductors, a connector without oil stop is mandatory.

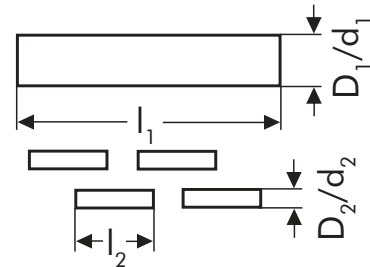

Specifications and standards

Heat-shrinkable tubes meet the requirements of IEC 60684-247. The dimensions of the mechanical connectors, that have been tested according to IEC 61238-1-A or VDE 0220 part 100 respectively, correspond to DIN V 47640.

The complete heat-shrinkable SVMS/SVMS-P joint meets the requirements of CENELEC EN 50393.



Kit contents

The heat-shrinkable in-line joints comprise the following components:

- 4 (5) x inner joints
- 1 x overall protection tube
- 4 (5) x mechanical connectors with/without oil stop
- installation instructions

SVMS HEAT-SHRINKABLE IN-LINE JOINT incl. mechanical connectors with oil stop up to 0.6/1 (1.2) kV, without parking position for the connectors on the conductors

Joint type	Dimensions outer tubes			Dimensions inner tubes			Ordering part number	
	l_1	D_1/d_1	Qty. / KIT	l_2	D_2/d_2	Qty. / KIT		
SVMS Gr. 1	4 x 4-16	360	43/12	1	100	15/4	4	53182
SVMS Gr. 1B	5 x 4-16	360	43/12	1	100	15/4	5	53619
SVMS Gr. 2	4 x 16 ¹⁾ -35	370	55/16	1	100	22/6	4	53183
SVMS Gr. 3	4 x 25-50	440	70/21	1	130	22/6	4	53184
SVMS Gr. 4	4 x 35-95	630	85/25	1	160	33/8	4	53185
SVMS Gr. 5	4 x 35-150	780	110/26	1	210	33/8	4	53186
SVMS Gr. 6	4 x 95-150	780	110/26	1	210	43/12	4	53187
SVMS Gr. 7	4 x 95 ¹⁾ -240	950	130/36	1	260	43/12	4	53188

¹⁾ Only for PVC-insulated cables according to DIN VDE 0276-603.

SVMS-P HEAT-SHRINKABLE IN-LINE JOINT incl. mechanical connectors without oil stop up to 0.6/1 (1.2) kV, with parking position for the connectors on the conductors

Joint type	Dimensions outer tubes			Dimensions inner tubes			Ordering part number	
	l_1	D_1/d_1	Qty. / KIT	l_2	D_2/d_2	Qty. / KIT		
SVMS-P Gr. 1	4 x 4-16	420	43/12	1	120	15/4	4	53189
SVMS-P Gr. 1B	5 x 4-16	420	43/12	1	120	15/4	5	57768
SVMS-P Gr. 2	4 x 16 ¹⁾ -35	430	55/16	1	120	22/6	4	53190
SVMS-P Gr. 3	4 x 25-50	500	70/21	1	155	22/6	4	53191
SVMS-P Gr. 4	4 x 35-95	710	85/25	1	190	33/8	4	53192
SVMS-P Gr. 5	4 x 35-150	890	110/26	1	250	33/8	4	53193
SVMS-P Gr. 6	4 x 95-150	890	110/26	1	250	43/12	4	53194
SVMS-P Gr. 7	4 x 95 ¹⁾ -240	1100	130/36	1	330	43/12	4	53195

¹⁾ Only for PVC-insulated cables according to DIN VDE 0276-603.

Ordering instructions

Select the order part number of the joint type according to the cable type and the conductor cross-section.

Example

Heat-shrinkable in-line joint for four-core polymeric insulated cable without parking position, nominal voltage 0.6/1 kV, conductor cross-section 35-150 mm²
Part number: 53186

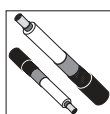

For use with other cross-sections please contact our representative.



For use with other cables please contact our representative.

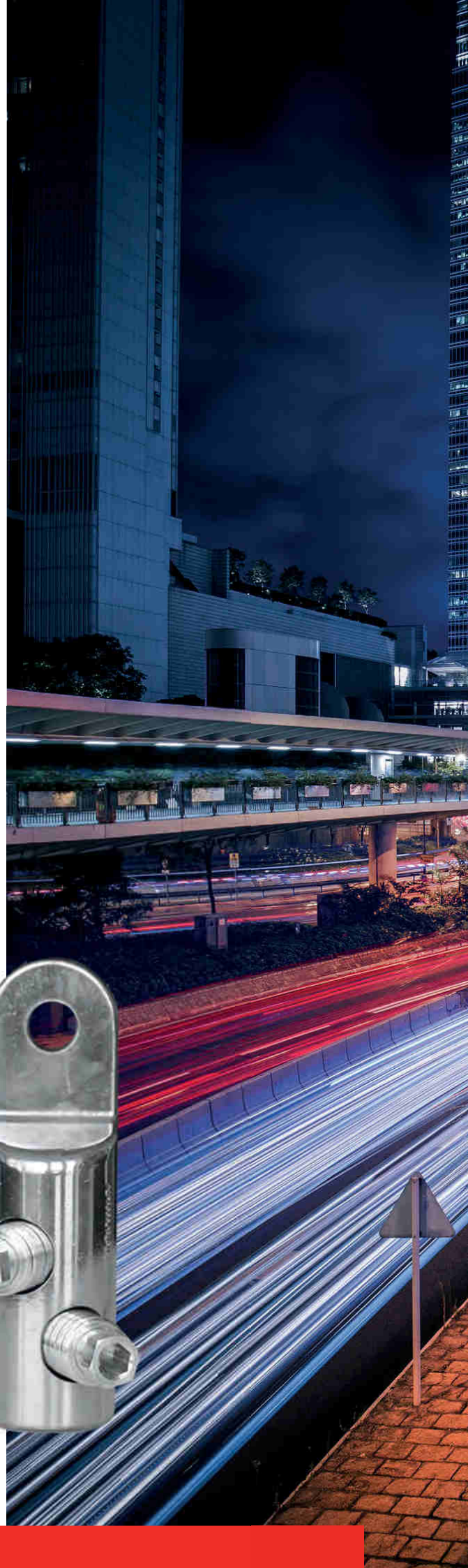
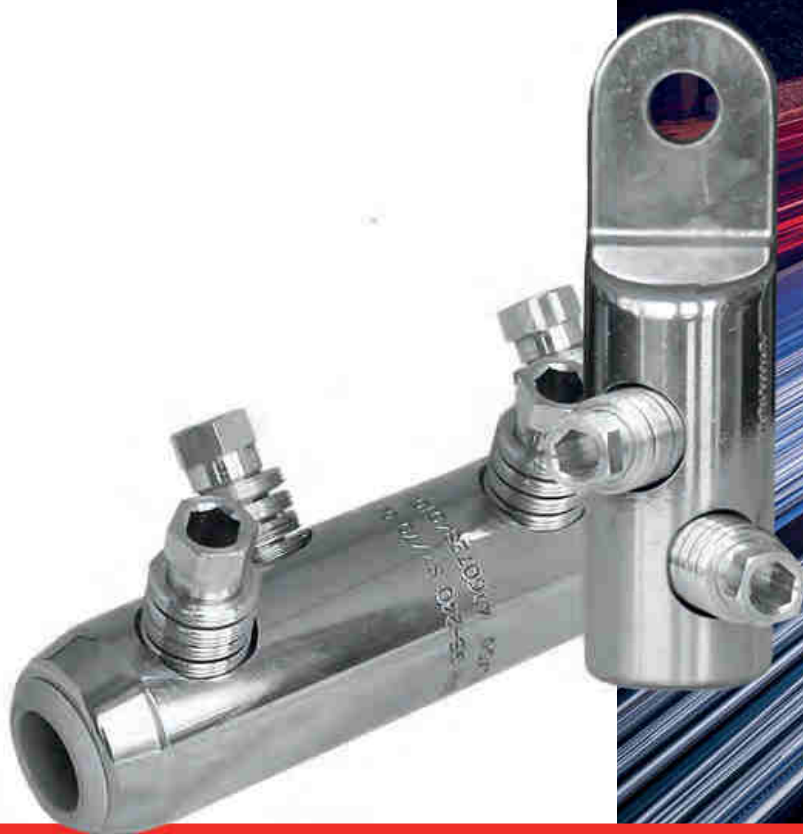

A long-exposure photograph of a city at night, featuring a multi-lane highway with light trails from cars. The background is filled with illuminated skyscrapers and modern buildings. The overall color palette is dominated by blues and greys, with warm reds and oranges from the light trails and streetlights.

GPH[®]
CONNECTION TECHNOLOGY
up to 52 kV

GPH® D-SERIES

Mechanical Connectors up to 0.6/1 kV

with sector channel, hexagon socket bolts or shear-off-head bolts

Application

Using GPH® D-Series low voltage mechanical connectors allows the connection of both identical and different conductor cross-sections, irrespective of the conductor material, shape and design.

Advantages

- **Simple, quick installation:**
With common commercially available inner and outer hexagon tools or an approved impact wrench.
- **Minimum storage costs:**
The cross-section range from 1.5 mm² to 300 mm² is covered by just 3 types of connectors.

• Universal applicability:

Can be used for copper and aluminum conductors according to EN 60228 classes 1 & 2. For use with flexible copper conductors class 5, please contact us.

• Proven quality:

GPH® D-Series mechanical connectors allow long-lasting contact quality of the application.

Design

Material:

Connector body:

brass or high strength aluminum alloy

Bolts:

brass or high strength aluminum alloy, tin-plated, with inner and outer hexagon

Surface:

D ...-V: tin-plated

D25-185 SV-T-V-K



D1,5-16 SV-S-V-K

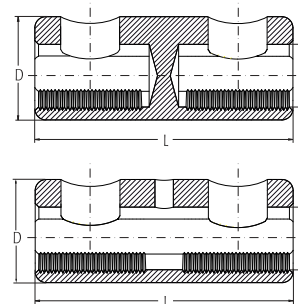

Bolts:

D ...: with hex. socket bolts

D ...-K: with shear-off-head bolts

Connector body:

D ...-S: with inspection hole

D ...-T: with oil stop

Mechanical connector type	AL acc. to EN 60228 (mm ²)				CU acc. to EN 60228 (mm ²)			CU Class 5 acc. to EN 60228 (mm ²)		Dimensions (mm)			Tool outer and inner hexagon	
	rm	sm	re	se	rm	sm	re	with contact sleeve	without contact sleeve	L	D	d	shear-off-head bolt	hexagon socket bolt
D1,5-16 SV(-T/-S)-V(-K) ^{1), 3)}	10-16		10-16		1,5-16		1,5-16	1,5-16		30	12	6.1	SW8	
D1,5-16 SV(-T/-S)-V ^{1), 3)}					1,5-16		1,5-16	1,5-16		30	12	6.1		SW3 ⁴⁾
D1,5-35 SV(-T/-S)-V(-K) ³⁾	10-35	35	10-35	35	1,5-35	35	1,5-35	1,5-35		36	16	9.0	SW5 ²⁾	
D10-35 SV(-T/-S)-V(-K) ³⁾	10-35	35	10-35	35	10-35	35	10-35	10-35		36	16	9.0	SW8	SW5
D25-50 SV(-T/-S)-V(-K)	25-50	35-50	25-50	35-50	25-50	35-50	25-35	50	25-35 ⁷⁾	36	18	10.0	SW8	SW5
D4-50 SV(-T/-S)-V(-K)	10-50	35-50	10-50	35-50	4-50	35-50	4-35	50	4-35 ⁷⁾	36	18	10.0	SW5 ²⁾	
D16-95 SV(-T/-S)-V(-K)	16-95	35-95	16-95	35-95	16-95	35-95	16-35	95	16-70 ⁷⁾	55	25	14.0	SW10	SW6
D25-150 SV(-T/-S)-V(-K)	25-150	35-150	25-150	35-150	25-150	35-150	16-35	120-150	25-95 ⁷⁾	70	28	17.0	SW6 ^{2), 5)}	
D35-150 SV(-T/-S)-V(-K)	35-150	35-150	50-150	50-150	35-150	35-150	35	120-150	35-95 ⁷⁾	70	28	17.0	SW13 ⁵⁾	SW6 ⁵⁾
D25-185 SV(-T/-S)-V(-K) ⁶⁾	25-185	35-185	25-185	35-185	25-185	35-185	25-35	150	25-120 ⁷⁾	80	32	19.0	SW6 ²⁾	
D70-185 SV(-T/-S)-V(-K) ⁶⁾	70-185	70-185	70-185	70-185	70-185	70-185		150-185	70-120 ⁷⁾	80	32	19.0	SW13	SW6
D50-240 SV(-T/-S)-V(-K) ⁶⁾	50-240	50-240	50-240	50-240	50-240	50-240		240	50-185 ⁷⁾	120	35	22.0	SW6 ²⁾	
D120-240 SV(-T/-S)-V(-K) ⁶⁾	120-240	120-240	120-240	120-240	120-240	120-240		240	120-185 ⁷⁾	120	35	22.0	SW13	SW6
D50-300 SV(-T/-S)-V(-K) ⁶⁾	50-300	50-300	50-300	50-300	50-240	50-240		240	95-185	128	38	23.0	SW8 ²⁾	
D150-300 SV(-T/-S)-V(-K) ⁶⁾	150-300	150-300	150-300	150-300	150-240	150-240		240	150-185	128	38	23.0	SW13	SW8

¹⁾ Connector Body: Brass

³⁾ Without sector channel

⁵⁾ Bolt, brass (tin plated)

⁷⁾ Contact sleeves available on request

²⁾ Double shear-off-head bolt

⁴⁾ Hexagon socket bolt, steel

⁶⁾ With four shear-off head bolts

Bolt system

We use grub screws with inner hexagons as well as single and multiple shear-off-head bolts that are equipped with an inner or outer hexagon. Both are related to the various shear-off-areas of the bolt and different torque moments.

The torque moments follow the rule that large conductor cross-sections need higher torque moments and smaller cross-sections need lower torque moments. The installation instruction describes the use of both hexagons for

the respective conductor types. Grub screws are tightened with the prescribed torque.

Ordering instructions

Please indicate the part number when ordering (see table).

Order example

1 mechanical connector for 50-240 mm², with oil stop. Order according to the table: 1 set of mechanical connectors D50-240 SV-T-V-K with part number G6602 17 27 (4ER-SET).

Mechanical connector type	Ordering part number
D1,5-16 SV-T-V-K D1,5-16 SV-S-V-K D1,5-16 SV-T-V D1,5-16 SV-S-V	G6603 01 01 G6603 01 02 G6603 01 03 G6603 01 04
D10-35 SV-T-V-K D10-35 SV-S-V-K D10-35 SV-T-V D10-35 SV-S-V	G6602 17 01 G6602 17 02 G6602 17 03 G6602 17 04
D4-50 SV-T-V-K D4-50 SV-S-V-K D25-50 SV-T-V-K D25-50 SV-S-V-K D25-50 SV-T-V D25-50 SV-S-V	G6602 17 05 G6602 17 06 G6602 17 07 G6602 17 08 G6602 17 09 G6602 17 10
D16-95 SV-T-V-K D16-95 SV-S-V-K D16-95 SV-T-V D16-95 SV-S-V	G6602 17 11 G6602 17 12 G6602 17 13 G6602 17 14
D25-150 SV-T-V-K D25-150 SV-S-V-K D35-150 SV-T-V-K D35-150 SV-S-V-K D35-150 SV-T-V D35-150 SV-S-V	G6602 17 15 G6602 17 16 (4ER-SET) G6602 17 17 G6602 17 18 G6602 17 19 G6602 17 20
D25-185 SV-T-V-K D25-185 SV-S-V-K D70-185 SV-T-V-K D70-185 SV-S-V-K D70-185 SV-T-V D70-185 SV-S-V	G6602 17 21 G6602 17 22 G6602 17 23 G6602 17 24 G6602 17 25 G6602 17 26
D50-240 SV-T-V-K D50-240 SV-S-V-K	G6602 17 27 (4ER-SET) G6602 17 28 (4ER-SET)
D50-300 SV-T-V-K D50-300 SV-S-V-K	G6602 17 44 G6602 17 43
D150-300 SV-T-V-K D150-300 SV-S-V-K	G6602 17 41 G6602 17 42

Specifications and standards

Mechanical connectors have been electrically tested according to IEC 61238-1-A or VDE 0220 part 100 respectively.

Product range

Please find the entire overview of our products for conductor connections in our catalogue GPH® Connection technology.

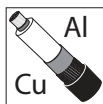

It is possible to connect different conductor materials.



It is possible to connect different conductor cross-sections.

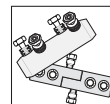

Different designs available.

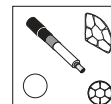

Can be used for all conductor shapes.

GPH® D-SERIES

Mechanical Cable Lugs up to 0.6/1 kV
with sector channel, hexagon socket bolts or shear-off-head bolts

Application

Using GPH® D-Series mechanical cable lugs allows larger conductor cross-section ranges even for low voltage applications, irrespective of the conductor material, shape and design. Mechanical cable lugs are standard tin-plated and offered with different palm hole diameters.

Advantages

- **Simple, quick installation:**
With common commercially available inner and outer hexagon tools or an approved impact wrench.
- **Minimum storage costs:**
The cross-section range from 1.5 mm² to 300 mm² is covered by just 3 types of cable lugs.
- **Universal applicability:**
Can be used for copper and aluminum conductors according to EN 60228 classes 1 & 2. For use with flexible copper conductors class 5, please contact us.
- **Proven quality:**
GPH® D-Series mechanical cable lugs allow long-lasting contact quality of the application.

Design

Material:

Connector body:

high strength aluminum alloy

Bolts:

high strength aluminum alloy, uncoated, with inner or outer hexagon

Surface:

D ...-V: tin-plated

D120-240 x 12 SK-V-K



Bolts:

D ...: with hex. socket bolts

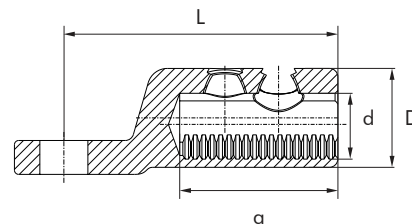

D ...-K: with shear-off-head bolts

Mechanical cable lug type	AL acc. to EN 60228 (mm ²)				CU acc. to EN 60228 (mm ²)			CU Class 5 acc. to EN 60228 (mm ²)		Dimensions (mm)				Tool outer and inner hexagon
	rm	sm	re	se	rm	sm	re	with contact sleeve	without contact sleeve	L	D	d	a	
D1,5-35 x 8(10) SK-V-K ²⁾	10-35	35	10-35	35	1,5-35	35	1,5-35	1,5-35		40	16	9,0	16	SW5 ¹⁾
D25-50 x 10(12) SK-V-K	25-50	35-50	25-50	35-50	25-50	35-50	25-35	50	25-35 ⁵⁾	40	18	10,0	16	SW8
D16-95 x 10(12) SK-V-K	16-95	35-95	16-95	35-95	16-95	35-95	16-35	95	16-70 ⁵⁾	52	25	14,0	24	SW10
D35-150 x 12(16) SK-V-K	35-150	35-150	50-150	50-150	35-150	35-150	35	120-150	35-95 ⁵⁾	60	28	17,0	31	SW13 ³⁾
D25-185 x 10(12/16) SK-V-K ⁴⁾	25-185	35-185	25-185	35-185	25-185	35-185	25-35	150	25-120 ⁵⁾	77	32	19,0	37	SW6 ¹⁾
D70-185 x 10(12/16) SK-V-K ⁴⁾	70-185	70-185	70-185	70-185	70-185	70-185		150-185	70-120 ⁵⁾	77	32	19,0	37	SW13
D120-240 x 12(16) SK-V-K ⁴⁾	120-240	120-240	120-240	120-240	120-240	120-240		240	120-185 ⁵⁾	97	35	22,0	56	SW13
D50-300 x 12(16) SK-V-K ⁴⁾	50-300	50-300	50-300	50-300	50-240	50-240		240	95-185	105	38	23,0	60	SW8 ¹⁾
D150-300 x 12(16) SK-V-K ⁴⁾	150-300	150-300	150-300	150-300	150-240	150-240		240	150-185	105	38	23,0	60	SW13

¹⁾ Double shear-off-head bolt

²⁾ Without sector channel

³⁾ Bolt, brass (tin-plated)

⁴⁾ With two shear-off-head bolts

⁵⁾ Contact sleeves available on request
Other palm holes on request.

Bolt system

We use grub screws with inner hexagons as well as single and multiple shear-off-head bolts that are equipped with an inner or outer hexagon. Both are related to the various shear-off-areas of the bolt and different torque moments.

The torque moments follow the rule that large conductor cross-sections need higher torque moments and smaller cross-sections need lower torque moments. The installation instruction describes the use of both hexagons for the

respective conductor types. Grub screws are tightened with the prescribed torque.

Ordering instructions

Please indicate the part number when ordering (see table).

Order example

1 mechanical cable lug for 120-240 mm², palm hole 12 mm.

Order according to the table:

1 mechanical cable lug D120-240 x 12 SK-V-K with part number G6702 54 12.

Mecanical cable lug	Ordering part number
D1,5-35 x 8 SK-V-K D1,5-35 x 10 SK-V-K	G6702 54 17 G6702 54 18
D25-50 x 10 SK-V-K D25-50 x 12 SK-V-K	G6702 54 21 G6702 54 14
D25-185 x 12 SK-V-K	G6702 54 31
D16-95 x 10 SK-V-K D16-95 x 12 SK-V-K	G6702 54 16 G6702 54 09
D35-150 x 12 SK-V-K D35-150 x 16 SK-V-K	G6702 54 13 G6702 54 23
D70-185 x 12 SK-V-K	G6702 54 32
D120-240 x 12 SK-V-K D120-240 x 16 SK-V-K	G6702 54 12 G6702 54 25
D50-300 x 12 SK-V-K D50-300 x 16 SK-V-K	G6702 54 33 G6702 54 34
D150-300 x 12 SK-V-K D150-300 x 16 SK-V-K	G6702 54 29 G6702 54 30

Specifications and standards

Mechanical connectors have been electrically tested according to IEC 61238-1-A or VDE 0220 part 100 respectively.

Product range

Please find the entire overview of our products for conductor connections in our catalogue GPH® Connection technology.

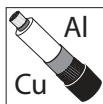

It is possible to connect different conductor materials.



It is possible to connect different conductor cross-sections.

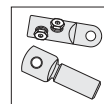

Different designs available.



Can be used for all conductor shapes.

GPH® M-SERIES

Mechanical Connectors up to 52 kV
with shear-off-head bolts and transverse grooving

Application

Our GPH® M-Series mechanical connectors are assembled with multiple shear-off-head bolts and are therefore a reliable and efficient way of connecting identical or different conductor cross-sections and conductor materials.

Advantages

- **Simple, quick installation:**
With common commercially available inner and outer hexagon tools or an approved impact wrench.
- **Minimum storage costs:**
The cross-section range from 16 mm² to 1200 mm² is covered by just 4 types of connectors.

Universal applicability:

Can be used for copper and aluminum conductors according to EN 60228 classes 1 & 2. For use of our mechanical connectors with class 5 flexible copper conductors, please contact us.

Proven quality:

Tested for class 2 conductors according to IEC 61238-1-A, in failure-free operation for more than 20 years.

Design

Material

Connector body: high strength aluminium alloy
Bolts: brass, tin-plated, with inner and outer hexagon

Surface

Connector body: tin-plated



M95-300

Centric conductor channel, with shear-off-head bolts and transverse grooving

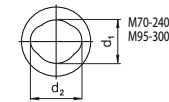
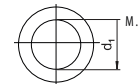
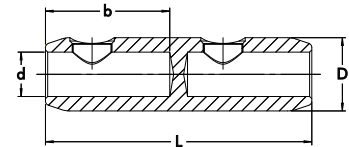

Mechanical connector type ⁴⁾	Conductor cross-section AL (mm ²)			Conductor cross-section CU (mm ²)		Number of bolts	Dimensions (mm)				Tool outer and inner hexagon
	rm(v)	re	sm	rm(v)	sm		L	d ₁	D	b	
M16-95	16-95	16-95	25-70	16-95	25-70	2	70	12.5	24	32	SW10 & SW6
M25-150	25-150	25-150	35-120	25-120	35-120	2	85	15.5	30	35	SW10 & SW6
M25-150/ 16-95	1 st side	25-150	25-150	35-120	25-120	2	85	15.5	30	35	SW10 & SW6
	2 nd side	16-95	10-95	25-70 ³⁾	16-95			25-70 ³⁾			
M70-240	70-240	70-240	70-240	70-240	70-240	4	120	22 ¹⁾	35	56	SW13 & SW6
M95-240	95-240	95-240	95-185	95-240	95-185	4	120	20	33	56	SW13 & SW6
M95-240/ 16-95	1 st side	95-240	95-240	95-185	95-240	4	120	20	33	56	SW13 & SW6
	2 nd side	16-95	10-95	25-70 ³⁾	16-95			25-70 ³⁾			
M95-300	95-300	95-300	95-240	70-300	70-240	4	142	23 ¹⁾	36	67	SW13 & SW8
M95-300/ 16-95	1 st side	95-300	95-300	95-240	70-300	4	142	23 ¹⁾	36	67	SW13 & SW8
	2 nd side	16-95	10-95	25-70 ³⁾	10-70			25-70 ³⁾			
M185-400	185-400	185-400	185-300	185-400	185-300	6	170	26	42	82	SW19 & SW6
M185-400/ 95-240	1 st side	185-400	185-400	185-300	185-400	6	170	26	42	82	SW19 & SW6
	2 nd side	95-240	95-240	95-185	95-240			95-185			
M300-500	300-500	300-500	300-400	300-500	300-400	6	200	34	52	94	SW19 & SW8
M400-630	400-630	400-630	400-500	400-630	400-500	6	200	34	52	94	SW19 & SW8
M400-630/ 120-300	1 st side	400-630	400-630	400-500	400-630	5	200	34	52	94	SW19 & SW8
	2 nd side	120-300	120-300	120-240	120-300			120-240			
M630-1000 ²⁾	630-1000	630-1000		630-1000		8	220	41	65	105	SW19 & SW8

¹⁾ Dimension d₂ = 26 mm

²⁾ Centric conductor positioning by center inserts

³⁾ Round pressed

⁴⁾ Other dimensions on request

M630-1000/ 185-400	1 st side ²⁾	630-1000	630-1000		630-1000		7	220	41	65	105	SW19 & SW8
	2 nd side	185-400	185-400	185-300	185-400	185-300			26		82	SW19

Technical details

Shear-off-head bolts are equipped with an inner and outer hexagon. Both are related to the various shear-off-areas of the bolt and different torque moments.

The torque moments follow the rule that large conductor cross-sections need higher torque moments and smaller cross-sections need lower torque moments.

The installation instruction describes the use of both hexagons and of the various center rings and inserts for the respective conductor types.

Centring of the conductor

For the centric positioning of smaller conductor cross-sections in the conductor channel, we use center rings that must be fully pressed into the channel of the connector before mounting

the corresponding conductor cross-section. The center rings differ in colour and are assigned to the respective type of conductor. Appropriate installation instructions describe for which

type of conductor the center rings are to be used. For using conductors of the largest cross-section range, center inserts are enclosed for centric conductor positioning.

Ordering instructions

Please indicate the part number when ordering (see table). The center rings or inserts are included in the set.

Order example

1 mechanical connector for 95-300 mm². Order according to the table: 1 mechanical connector M95-300 with part number G6402 51 47.

Mechanical connector type	Ordering part number
M16-95	G6402 50 31
M25-150 M25-150/16-95	G6402 50 15 G6402 50 37
M70-240	G6402 50 60
M95-240 M95-240/16-95	G6402 50 16 G6402 50 36
M95-300 M95-300/16-95	G6402 51 47 G6402 51 77
M185-400 M185-400/95-240	G6402 50 27 G6402 50 35
M300-500	G6402 50 62
M400-630 M400-630/120-300	G6402 50 44 G6402 50 54
M630-1000 M630-1000/185-400	G6402 51 10 G6402 51 11

Specifications and standards

Mechanical connectors have been electrically tested according to IEC 61238-1-A or VDE 0220 part 100 respectively.

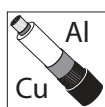

It is possible to connect different conductor materials.

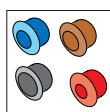

We use center rings for the centric positioning of small conductor cross-sections.

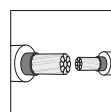

It is possible to connect different conductor cross-sections.

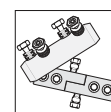

Different designs available.

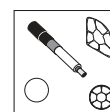

Can be used for all conductor shapes.

GPH® C-SERIES

Mechanical Cable Lugs up to 52 kV
with shear-off-head bolts and transverse grooving

Application

Using GPH® C-Series mechanical cable lugs allows a larger, multirange conductor cross-section even for terminations. Mechanical cable lugs are standard tin-plated and offered with different palm hole diameters.

Design

Material

Connector Body: high strength aluminium alloy
Bolts: brass, tin-plated, with inner and outer hexagon or aluminum alloy

Surface

Connector body: tin-plated

Advantages

- **Simple, quick installation:**
With common commercially available inner and outer hexagon tools or an approved impact wrench.
- **Minimum storage costs:**
The cross-section range from 16 mm² to 1200 mm² is covered by just 4 types of cable lugs.

• Universal applicability:

Can be used for copper and aluminum conductors according to EN 60228 classes 1 & 2. For use of our mechanical cable lugs with class 5 flexible copper conductors, please contact us.

• Proven quality:

Tested for class 2 conductors according to IEC 61238-1-A, in failure-free operation for more than 20 years.



Centric conductor channel, with shear-off-head bolts and transverse grooving

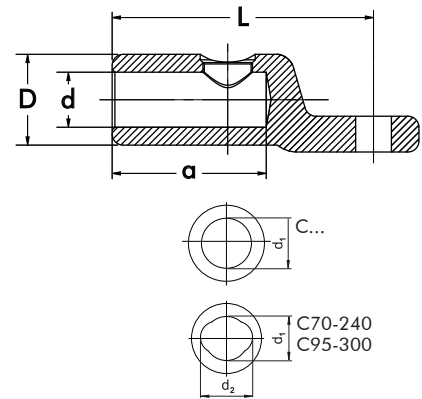

Mechanical cable lug type	Conductor cross-section AL (mm ²)			Conductor cross-section CU (mm ²)		Number of bolts	Dimensions (mm)				Palm hole dia. (mm)	Tool outer and inner hexagon
	rm(v)	re	sm	rm(v)	sm		L	d ₁	D	a		
C16-95 x 12	16-95	16-95	25-70	16-95	25-70	1	60	12.5	24	32	13	SW10 & SW6
C16-95 x 16											17	
C25-150 x 12	25-150	25-150	35-120	25-120	35-120	1	79	15.5	30	35	13	SW10 & SW6
C25-150 x 16											17	
C70-240 x 12	70-240	70-240	70-240	70-240	70-240	2	93,5	22 ¹⁾	35	56	13	SW13 & SW6
C70-240 x 16											17	
C95-240 x 12	95-240	95-240	95-185	95-240	95-185	2	95	20	33	56	13	SW13 & SW6
C95-240 x 16											17	
C95-300 x 12	95-300	95-300	95-240	70-300	70-240	2	105	23 ¹⁾	36	67	13	SW13 & SW8
C95-300 x 16											17	
C120-300 x 12	120-300	120-300	120-240	120-300	120-240	2	105	25	38	67	13	SW19 & SW6
C120-300 x 16											17	
C185-400 x 12	185-400	185-400	185-300	185-400	185-300	3	120	26	42	82	13	SW19 & SW6
C185-400 x 16											17	
C300-500 x 12	300-500	300-500	300-400	300-500	300-400	3	130	34	52	94	13	SW19 & SW8
C300-500 x 16											17	
C300-500 x 20											21	
C400-630 x 12	400-630	400-630	400-500	400-630	400-500	3	130	34	52	94	13	SW19 & SW8
C400-630 x 16											17	
C400-630 x 20											21	
C630-1000 x 20 ²⁾	630-1000	630-1000		630-1000		4	165	41	65	105	21	SW19 & SW8
C800-1200 x 20 ²⁾	800-1200	630-1200		630-1000		4	170	45	72	105	21	SW22 & SW8

¹⁾ Dimension d₂=26 mm

²⁾ Centric conductor positioning by center inserts

Technical details

Shear-off-head bolts are equipped with an inner and outer hexagon. Both are related to the various shear-off-areas of the bolt and different torque moments corresponding.

The torque moments follow the rule that large conductor cross-sections need higher torque moments and smaller cross-sections need lower torque moments.

The installation instruction describes the use of both hexagons and of the various center rings and inserts for the respective conductor types.

Centring of the conductor

For the centric positioning of smaller conductor cross-sections in the conductor channel, we use center rings that must be fully pressed into the channel of the cable lug before mounting the corre-

sponding conductor cross-section. The center rings differ in colour and are assigned to the respective type of conductor. Appropriate installation instructions describe for which type of conductor the center

rings are to be used. For using conductors of the largest cross-section range, a center insert is enclosed for centric conductor positioning.

Ordering instructions

Please indicate the part number when ordering (see table). The center rings or inserts are included in the set.

Order example:

1 mechanical cable lug for 95-300 mm², palm hole dia. 17 mm.
Order according to the table:
1 mechanical cable lug C95-300 x 16 with part number G6502 40 92.

Mechanical cable lug type	Ordering part number
C16-95 x 12	G6502 40 20
C16-95 x 16	G6502 40 33
C25-150 x 12	G6502 40 09
C25-150 x 16	G6502 40 84
C70-240 x 12	G6502 40 36
C70-240 x 16	G6502 40 40
C95-240 x 12	G6502 40 10
C95-240 x 16	G6502 40 17
C95-300 x 12	G6502 40 88
C95-300 x 16	G6502 40 92
C120-300 x 12	G6502 40 23
C120-300 x 16	G6502 40 26
C185-400 x 12	G6502 40 30
C185-400 x 16	G6502 40 19
C300-500 x 12	G6502 40 34
C300-500 x 16	G6502 40 37
C300-500 x 20	G6502 40 41
C400-630 x 12	G6502 40 28
C400-630 x 16	G6502 40 31
C400-630 x 20	G6502 40 29
C630-1000 x 20	G6502 51 10
C800-1200 x 20	G6502 51 12

Specifications and standards

Mechanical connectors have been electrically tested according to IEC 61238-1-A or VDE 0220 part 100 respectively.

Product range

Please find the entire overview of our products for conductor connections in our catalogue GPH® connection technology.

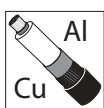

It is possible to connect different conductor materials.

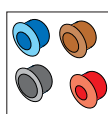

We use center rings for the centric positioning of small conductor cross-sections.

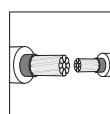

It is possible to connect different conductor cross-sections.

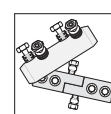

Different designs available.

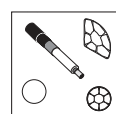

Can be used for all conductor shapes.

GPH® Compression cable lugs, Cu

Standard type, with and without inspection hole

Application

For isolated, non-compacted copper conductors acc. to DIN EN 60228.

Technical note

Sector shaped conductors must be rounded with special dies.

Product range

Please find the entire overview of our products for conductor connections in our catalogues GPH® Connection technology.

Design

Material

Connector body: Copper, tin-plated
Palm: plan stamped

Type

KU-L: without inspection hole

KU-L-S: with inspection hole



KU-L



KU-L-S

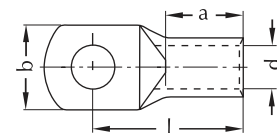

The compression of the KU-L series does not accord to the DIN requirements. Special compression tools are available on request.

Cable lug type		Conductor cross-section, stranded (mm ²)	Dimensions (mm)				Palm hole dia. (mm)	Weight 100 pcs. (approx. kg)
KU-L	KU-L-S		d	a	l	b		
6 x 5 KU-L	6 x 5 KU-L-S	6	3.5	9	21	10.5	5.4	0.4
6 x 6 KU-L	6 x 6 KU-L-S				21	11.5	6.5	0.4
6 x 8 KU-L	6 x 8 KU-L-S				21	15.5	8.5	0.4
6 x 10 KU-L	6 x 10 KU-L-S				21	17.0	10.5	0.5
10 x 5 KU-L	10 x 5 KU-L-S	10	4.5	9	21	12.0	5.5	0.4
10 x 6 KU-L	10 x 6 KU-L-S				21	12.0	6.5	0.4
10 x 8 KU-L	10 x 8 KU-L-S				23	14.5	8.5	0.4
10 x 10 KU-L	10 x 10 KU-L-S				25.5	17.0	10.5	0.5
16 x 5 KU-L	16 x 5 KU-L-S	16	5.5	12	26	12.0	5.5	0.5
16 x 6 KU-L	16 x 6 KU-L-S				26	12.0	6.5	0.7
16 x 8 KU-L	16 x 8 KU-L-S				28	13.5	8.5	0.8
16 x 10 KU-L	16 x 10 KU-L-S				30	17.0	10.5	0.8
16 x 12 KU-L	16 x 12 KU-L-S	32	20.0	13.0	0.8			
25 x 6 KU-L	25 x 6 KU-L-S	25	7.0	13	27	14.0	6.5	1.0
25 x 8 KU-L	25 x 8 KU-L-S				29	16.0	8.5	1.0
25 x 10 KU-L	25 x 10 KU-L-S				33	17.5	10.5	1.1
25 x 12 KU-L	25 x 12 KU-L-S				34	20.0	13.0	1.0
35 x 6 KU-L	35 x 6 KU-L-S	35	8.5	15	31	18.0	6.5	1.0
35 x 8 KU-L	35 x 8 KU-L-S				32	18.0	8.5	1.0
35 x 10 KU-L	35 x 10 KU-L-S				34	18.0	10.5	1.1
35 x 12 KU-L	35 x 12 KU-L-S				37	22.0	13.0	1.0

GPH® Compression cable lugs, Cu

Standard type, with and without inspection hole

Table on page 76 continued

Cable lug type		Conductor cross-section, stranded (mm ²)	Dimensions (mm)				Palm hole dia. (mm)	Weight 100 pcs. (approx. kg)
KU-L	KU-L-S		d	a	l	b		
50 x 8 KU-L	50 x 8 KU-L-S	50	3.5	9	21	10.5	5.4	0.4
50 x 10 KU-L	50 x 10 KU-L-S				21	11.5	6.5	0.4
50 x 12 KU-L	50 x 12 KU-L-S				21	15.5	8.5	0.4
50 x 16 KU-L	50 x 16 KU-L-S				21	17.0	10.5	0.5
70 x 8 KU-L	70 x 8 KU-L-S	70	12.0	19	41	23.0	8.5	3.5
70 x 10 KU-L	70 x 10 KU-L-S				40	23.0	10.5	3.6
70 x 12 KU-L	70 x 12 KU-L-S				42	23.0	13.0	3.6
70 x 16 KU-L	70 x 16 KU-L-S				50	29.0	17.0	3.6
70 x 20 KU-L	70 x 20 KU-L-S				52	31.0	21.0	4.6
95 x 8 KU-L	95 x 8 KU-L-S	95	13.5	22	48	25.0	8.5	4.7
95 x 10 KU-L	95 x 10 KU-L-S				48	25.0	10.5	4.8
95 x 12 KU-L	95 x 12 KU-L-S				48	25.0	13.0	4.9
95 x 16 KU-L	95 x 16 KU-L-S				53	31.0	17.0	5.3
95 x 20 KU-L	95 x 20 KU-L-S				58	31.0	21.0	6.1
120 x 10 KU-L	120 x 10 KU-L-S	120	15.0	25	54	28.0	10.5	6.7
120 x 12 KU-L	120 x 12 KU-L-S				54	28.0	13.0	6.7
120 x 16 KU-L	120 x 16 KU-L-S				56	29.0	17.0	6.9
120 x 20 KU-L	120 x 20 KU-L-S				59	34.0	21.0	6.9
150 x 10 KU-L	150 x 10 KU-L-S	150	16.5	27	57	31.0	10.5	8.8
150 x 12 KU-L	150 x 12 KU-L-S				58	31.0	13.0	8.6
150 x 16 KU-L	150 x 16 KU-L-S				59	31.0	17.0	8.7
150 x 20 KU-L	150 x 20 KU-L-S				61	33.0	21.0	8.8
185 x 12 KU-L	185 x 12 KU-L-S	185	19.0	30	66	35.0	13.0	11.5
185 x 16 KU-L	185 x 16 KU-L-S				66	35.0	17.0	11.6
185 x 20 KU-L	185 x 20 KU-L-S				68	35.0	21.0	11.8
240 x 12 KU-L	240 x 12 KU-L-S	240	21.0	34	75		13.0	13.9
240 x 16 KU-L	240 x 16 KU-L-S				71	38.0	17.0	13.6
240 x 20 KU-L	240 x 20 KU-L-S				73	21.0	21.0	13.8
300 x 12 KU-L	300 x 12 KU-L-S	300	24.0	45	90		13.0	23.8
300 x 16 KU-L	300 x 16 KU-L-S				87	43.0	17.0	23.7
300 x 20 KU-L	300 x 20 KU-L-S				87	21.0	21.0	23.8
400 x 16 KU-L	400 x 16 KU-L-S	400	27.5	50	96		17.0	28.4
400 x 20 KU-L	400 x 20 KU-L-S					48.0	21.0	28.5
500 x 16 KU-L	500 x 16 KU-L-S	500	31.0	65	122		17.0	45.2
500 x 20 KU-L	500 x 20 KU-L-S					55.0	21.0	46.9
625 x 16 KU-L	625 x 16 KU-L-S	625	34.0	70	124		17.0	43.9
625 x 20 KU-L	625 x 20 KU-L-S					59.0	21.0	46.9

15-01-2019

GPH® Compression cable lugs, Cu

Acc. to DIN 46235

Application

For isolated, non-compacted copper conductors.

Technical note

Sector shaped conductors must be rounded with special dies.

Product range

Please find the entire overview of our products for conductor connections in our catalogue GPH® Connection technology.

Design

Material

Connector body: Copper

Surface

KU: uncoated
KU-V: tin-plated



Cable lug type		Conductor cross-section, stranded (mm ²)	Dimensions (mm)			Palm hole dia. (mm)	Die code no.	Number of compressions		Weight 100 pcs. (approx. kg)
KU	KU-V		d	l	b			mech.	hydr.	
6 x 5 KU 6 x 6 KU	6 x 5 KU-V 6 x 6 KU-V	6	3.8	24	8.5	5.4 6.5	5	1		0.6
10 x 5 KU 10 x 6 KU	10 x 5 KU-V 10 x 6 KU-V	10	4.5	27	9.0	5.4 6.5	6	1		0.6
10 x 6 KU-S ¹⁾ 10 x 8 KU-S ¹⁾ 10 x 10 KU-S ¹⁾ 10 x 12 KU-S ¹⁾	10 x 6 KU-S-V ¹⁾ 10 x 8 KU-S-V ¹⁾ 10 x 10 KU-S-V ¹⁾ 10 x 12 KU-S-V ¹⁾	10	4.5	36 36 36 38	13.0 13.0 17.0 20.0	6.5 8.5 10.5 13.0	8	2		1.8 1.7 1.8 1.9
16 x 6 KU 16 x 8 KU 16 x 10 KU 16 x 12 KU ²⁾	16 x 6 KU-V 16 x 8 KU-V 16 x 10 KU-V 16 x 12 KU-V ²⁾	16	5.5	36	13.0 13.0 17.0 21.0	6.5 8.5 10.5 13.0	8	2	1	1.8 1.4 1.5 1.7
25 x 6 KU ²⁾ 25 x 8 KU 25 x 10 KU 25 x 12 KU 25 x 16 KU	25 x 6 KU-V ²⁾ 25 x 8 KU-V 25 x 10 KU-V 25 x 12 KU-V 25 x 16 KU-V	25	7.0	38 42	14.0 16.0 17.0 19.0 25.0	6.5 8.5 10.5 13.0 17.0	10	2	1	2.2 2.1 2.2 2.2 2.4
35 x 6 KU ²⁾ 35 x 8 KU 35 x 10 KU 35 x 12 KU 35 x 16 KU ²⁾	35 x 6 KU-V ²⁾ 35 x 8 KU-V 35 x 10 KU-V 35 x 12 KU-V 35 x 16 KU-V ²⁾	35	8.2	42 46	17.0 17.0 19.0 21.0 26.0	6.5 8.5 10.5 13.0 17.0	12	2	1	3.6 3.3 3.5 3.3 3.7

¹⁾ These cable lugs are longer than DIN-type lugs, with two compression marks instead of one and die code no. 8 instead no. 6.

²⁾ These cable lugs are manufactured as a special model, different from DIN 46235.

GPH® Compression cable lugs, Cu

Acc. to DIN 46235

Table on page 78 continued

Cable lug type		Conductor cross-section, stranded (mm ²)	Dimensions (mm)			Palm hole dia. (mm)	Die code no.	Number of compressions		Weight 100 pcs. (approx. kg)
KU	KU-V		d	l	b			mech.	hydr.	
50 x 8 KU	50 x 8 KU-V	50	10.0	52	20.0	8.5	14	3	1	4.4
50 x 10 KU	50 x 10 KU-V				22.0	10.5				4.5
50 x 12 KU	50 x 12 KU-V				24.0	13.0				4.4
50 x 16 KU	50 x 16 KU-V				28.0	17.0				5.0
70 x 8 KU	70 x 8 KU-V	70	11.5	55	24.0	8.5	16	3	1	6.1
70 x 10 KU	70 x 10 KU-V				24.0	10.5				6.1
70 x 12 KU	70 x 12 KU-V				24.0	13.0				6.2
70 x 16 KU	70 x 16 KU-V				30.0	17.0				5.9
70 x 20 KU	70 x 20 KU-V				32.0	21.0				7.0
95 x 10 KU	95 x 10 KU-V	95	13.5	65	28.0	10.5	18	4	2	9.2
95 x 12 KU	95 x 12 KU-V				28.0	13.0				9.2
95 x 16 KU	95 x 16 KU-V				32.0	17.0				9.1
95 x 20 KU ²⁾	95 x 20 KU-V ²⁾				34.0	21.0				10.4
120 x 10 KU	120 x 10 KU-V	120	15.5	70	32.0	10.5	20	4	2	11.4
120 x 12 KU	120 x 12 KU-V				32.0	13.0				11.6
120 x 16 KU	120 x 16 KU-V				32.0	17.0				11.0
120 x 20 KU	120 x 20 KU-V				38.0	21.0				12.8
150 x 10 KU	150 x 10 KU-V	150	17.0	78	34.0	10.5	22	4	2	16.9
150 x 12 KU	150 x 12 KU-V				34.0	13.0				16.4
150 x 16 KU	150 x 16 KU-V				34.0	17.0				16.3
150 x 20 KU	150 x 20 KU-V				40.0	21.0				17.0
185 x 10 KU	185 x 10 KU-V	185	19.0	82	37.0	10.5	25	5	2	19.3
185 x 12 KU	185 x 12 KU-V				37.0	13.0				19.4
185 x 16 KU	185 x 16 KU-V				37.0	17.0				19.1
185 x 20 KU	185 x 20 KU-V				40.0	21.0				20.0
240 x 12 KU	240 x 12 KU-V	240	21.5	92	42.0	13.0	28	5	2	28.5
240 x 16 KU	240 x 16 KU-V				42.0	17.0				28.9
240 x 20 KU	240 x 20 KU-V				45.0	21.0				28.0
300 x 12 KU ²⁾	300 x 12 KU-V ²⁾	300	24.5	100	48.0	13.0	32		2	38.1
300 x 16 KU	300 x 16 KU-V				48.0	17.0				37.5
300 x 20 KU	300 x 20 KU-V				48.0	21.0				38.5
400 x 16 KU ³⁾	400 x 16 KU-V ³⁾	400	26.0	115	55.0	17.0	38		3	79.8
400 x 20 KU ³⁾	400 x 20 KU-V ³⁾				55.0	21.0				76.6
500 x 16 KU ³⁾	500 x 16 KU-V ³⁾	500	29.0	125	60.0	17.0	42		3	97.8
500 x 20 KU ³⁾	500 x 20 KU-V ³⁾				60.0	21.0				96.0
400 x 16 KU-S	400 x 16 KU-S-V	400	27.5	115	55.0	17.0	38		3	68.8
400 x 20 KU-S	400 x 20 KU-S-V				55.0	21.0				66.0
500 x 16 KU-S	500 x 16 KU-S-V	500	31.0	125	60.0	17.0	42		3	85.0
500 x 20 KU-S	500 x 20 KU-S-V				60.0	21.0				83.5
625 x 16 KU	625 x 16 KU-V	625	34,5	135	60.0	17.0	44		3	79.4
625 x 20 KU	625 x 20 KU-V				60.0	21.0				77.9
800 x 20 KU	800 x 20 KU-V	800	40.0	165	75.0	21.0	52		3	146.9
1000 x 20 KU	1000 x 20 KU-V	1000	44.0	165	85.0	21.0	58		3	191.1

¹⁾ These cable lugs are longer than DIN-type lugs, with two compression marks instead of one and die code no. 8 instead no. 6.

²⁾ These cable lugs are manufactured as a special model, different from DIN 46235.

³⁾ Inside diameter adapted.

GPH® Compression cable lugs, Al

Longitudinally sealed, acc. to DIN 46329

Application

For aluminum conductors and aluminum cable conductors

Technical note

Sector shaped conductors must be rounded with special dies.

Design

Material

Connector body: Aluminum
Palm: plan stamped

Surface

ALU-F: uncoated
ALU-F-V: tin-plated

Cable lugs filled with compound and sealed in plastic.



ALU-F



ALU-F-V

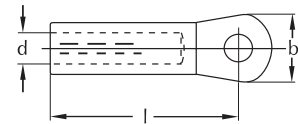

Cable lug type		Conductor cross-section (mm ²)		Dimensions (mm)			Palm hole dia. (mm)	Die code no.	Number of compressions		Weight 100 pcs. (approx. kg)
ALU-F	ALU-F-V	rm/sm	se	d	l	b			mech.	hydr.	
16 x 8 ALU-F ¹⁾	16 x 8 ALU-F-V ¹⁾	16	25	5.4	50	20	8.5	12	4	2	1.4
16 x 10 ALU-F ¹⁾	16 x 10 ALU-F-V ¹⁾					25	10.5				1.3
25 x 8 ALU-F ¹⁾	25 x 8 ALU-F-V ¹⁾	25	35	6.8	50	20	8.5	12	4	2	1.5
25 x 10 ALU-F ¹⁾	25 x 10 ALU-F-V ¹⁾					25	10.5				1.4
25 x 12 ALU-F ¹⁾	25 x 12 ALU-F-V ¹⁾					25	13.0				1.4
35 x 8 ALU-F	35 x 8 ALU-F-V	35	50	8.0	62	25	8.5	14	5	2	2.6
35 x 10 ALU-F	35 x 10 ALU-F-V					25	10.5				2.4
35 x 12 ALU-F	35 x 12 ALU-F-V					25	13.0				2.3
50 x 8 ALU-F	50 x 8 ALU-F-V	50	70	9.8	62	25	8.5	16	5	2	2.5
50 x 10 ALU-F	50 x 10 ALU-F-V					25	10.5				2.4
50 x 12 ALU-F	50 x 12 ALU-F-V					25	13.0				2.3
70 x 8 ALU-F	70 x 8 ALU-F-V	70	95	11.2	72	25	8.5	18	6	3	3.5
70 x 10 ALU-F	70 x 10 ALU-F-V					25	10.5				3.3
70 x 12 ALU-F	70 x 12 ALU-F-V					25	13.0				
95 x 8 ALU-F	95 x 8 ALU-F-V	95	120	13.2	78	25	8.5	22	6	3	7.4
95 x 10 ALU-F	95 x 10 ALU-F-V				78	25	10.5				7.0
95 x 12 ALU-F	95 x 12 ALU-F-V				78	25	13.0				6.7
95 x 16 ALU-F	95 x 16 ALU-F-V				80	30	17.0				
120 x 10 ALU-F	120 x 10 ALU-F-V	120	150	14.7	84	30	10.5	22	6	3	6.8
120 x 12 ALU-F	120 x 12 ALU-F-V					30	13.0				6.5
120 x 16 ALU-F	120 x 16 ALU-F-V					30	17.0				
150 x 10 ALU-F	150 x 10 ALU-F-V	150	185	16.3	90	30	10.5	25	6	3	8.8
150 x 12 ALU-F	150 x 12 ALU-F-V					30	13.0				8.4
150 x 16 ALU-F	150 x 16 ALU-F-V					30	17.0				9.3

¹⁾ Palm width and height do not comply with DIN 46329.

GPH® Compression cable lugs, Al

Longitudinally sealed, acc. to DIN 46329

Product range

Please find the entire overview of our products for conductor connections in our catalogue GPH® Connection technology.

Table on page 80 continued

Cable lug type		Conductor cross-section (mm ²)		Dimensions (mm)			Palm hole dia. (mm)	Die code no.	Number of compressions		Weight 100 pcs. (approx. kg)	
ALU-F	ALU-F-V	rm/sm	se	d	l	b			mech.	hydr.		
185 x 10 ALU-F	185 x 10 ALU-F-V	185	240	18.3	91	30	10.5	28	6	3	11.1	
185 x 12 ALU-F	185 x 12 ALU-F-V						13.0				11.0	
185 x 16 ALU-F	185 x 16 ALU-F-V						17.0				11.2	
240 x 12 ALU-F	240 x 12 ALU-F-V	240	300	21.0	103	38	13.0	32	8	3	15.9	
240 x 16 ALU-F	240 x 16 ALU-F-V						17.0				15.5	
240 x 20 ALU-F	240 x 20 ALU-F-V						21.0				16.2	
300 x 12 ALU-F	300 x 12 ALU-F-V	300		23.3	103	38	13.0	34	8	3	17.4	
300 x 16 ALU-F	300 x 16 ALU-F-V						17.0					19.1
300 x 20 ALU-F	300 x 20 ALU-F-V						21.0					
400 x 12 ALU-F	400 x 12 ALU-F-V	400		26.0	116	38	13.0	38		3	34.0	
400 x 16 ALU-F	400 x 16 ALU-F-V						17.0					35.5
400 x 20 ALU-F	400 x 20 ALU-F-V						21.0					
500 x 12 ALU-F	500 x 12 ALU-F-V	500		29.0	122	44	13.0	44		4	40.5	
500 x 16 ALU-F	500 x 16 ALU-F-V						17.0					40.3
500 x 20 ALU-F	500 x 20 ALU-F-V						21.0					

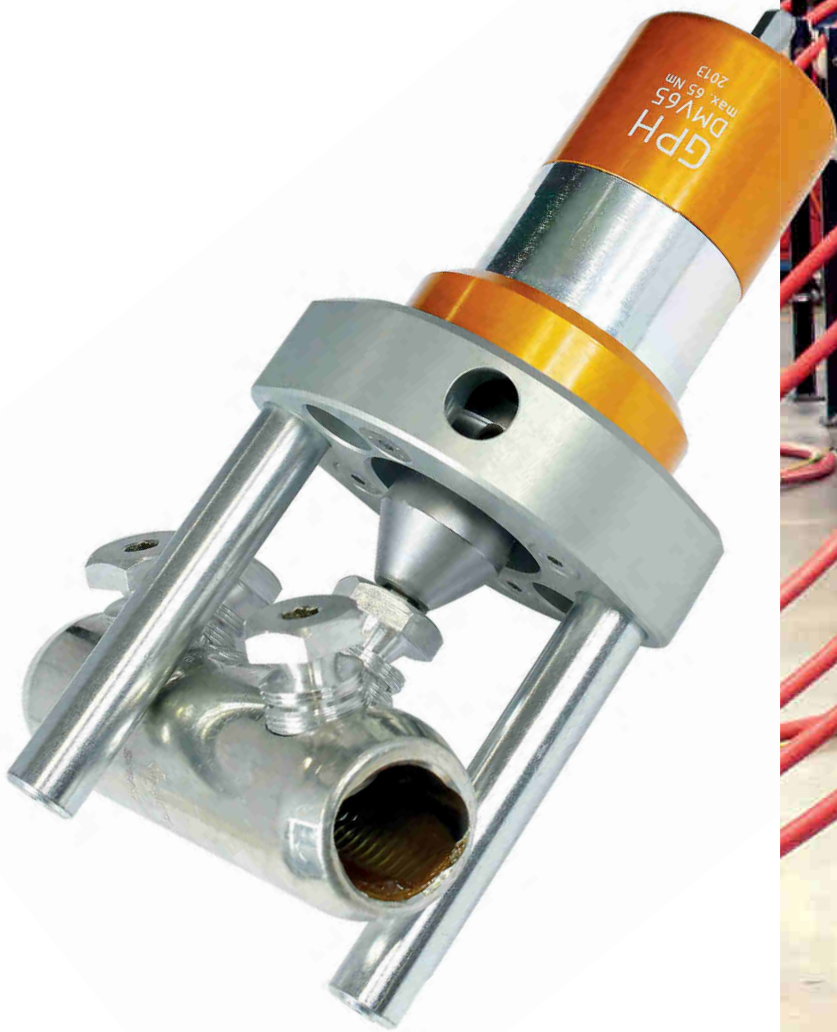

6A

TOOLS

for the installation of power accessories



CABLE PREPARATION TOOLS

for accessories installation in medium voltage applications

Peeling tool with stop ring, size 1



Order numbers: peeling tool 51494 / spare cutter 51495

The peeling tool is suitable for removing the extruded outer semi-conductive cable screen of medium voltage cables. Field of application: 10 kV 25 mm² up to 30 kV 500 mm² cables, diameter over core insulation between 10 mm up to 52 mm. The cutting depth is preset for semi-con screens acc. to VDE 0276 part 620. In case of thicker screens

than described, the cutting depth of the blade can be adjusted up to a maximum of 1.2 mm. By using the tool with length control the semi-con layer can be removed between 25 mm up to 100 mm measured from cut-off edge of outer cable sheath. Stop rings included in the kit.

2-in-1 Cable sheath and cable insulation cutter, size 1



Order numbers: cable sheath 59117 / spare cutter 51488

The tool is engineered for professional and safe stripping of the outer cable sheath of medium voltage cables. Field of application: 10 kV 25 mm² up to 30 kV 500 mm² single-core cables, diameter over outer sheath between 15 mm up to 57 mm. The tool is also suitable for removing polymeric insulation of medium voltage cables in the aforementioned range. It has been

designed to provide spiral cutting (longitudinal) as well as circumferential cutting. The blade is specially formed with a guiding system lifting the material while cutting it to avoid any damages to the layers underneath. Cutting depth is adjustable.

Chamfering tool, size 1



Order numbers: chamfering tool 43523 / spare cutter 44129

This very simple to handle tool removes sharp edges at the cut-off edge of cable insulation to avoid possible damage to and to ease installation of slip-on accessories. Field of application: 10 kV 25 mm² up to 30 kV 500 mm² cables acc. to VDE 0276 part 620, diameter over core insulation between 12 mm up to 45 mm after peeling the outer

sheath. Due to its specially formed blade a radius is produced at the cut-off edge. This reduces the force required to install non-size sensitive slip-on accessories enormously.

Insulation stripping tool



Order numbers: 40001 for 10 kV; 40002 for 20 kV; 40003 for 30 kV
Order numbers: spare cutter 41083 for 10 kV; 41084 for 20 kV; 41085 for 30 kV

Tool for removing the core insulation of PVC or XLPE insulated medium voltage cables. Separate tools for voltage level of 10 kV, 20 kV and 30 kV can be delivered. Therefore, no adjustment of voltage level or

conductor cross-section is necessary. The simple exchange of blades with preset cutting depth prevents damaging the cable conductor.

CABLE PREPARATION TOOLS

for accessories installation in medium voltage applications
and cables with conductor cross-sections > 500 mm²

I Peeling tool with stop ring, size 2



Order numbers: peeling tool 55152 / spare cutter 51495

The peeling tool is suitable for removing the extruded outer semi-conductive cable screen of medium voltage cables with diameters over core insulation between 10 mm up to 60 mm. The cutting depth is preset for semi-con screens acc. to VDE 0276 part 620. In case of thicker screens than described, the cutting depth of the blade can be

adjusted up to a maximum of 1.2 mm. By using the tool with length control the semi-con layer can be removed between 25 mm up to 100 mm measured from cut-off edge of outer cable sheath. Stop rings included in the kit.

I 2-in-1 Cable sheath and cable insulation cutter, size 2



Order numbers: cable sheath 59118 / spare cutter 55541

The tool is engineered for professional and safe stripping of the outer cable sheath of medium voltage single-core cables with diameters over outer sheath between 32 mm up to 70 mm. The tool is also suitable for removing polymeric insulation of medium voltage cables in the afore mentioned range. It has been designed to provide spiral cutting (longitudinal)

as well as circumferential cutting. The blade is specially formed with a guiding system lifting the material while cutting it to avoid any damages to the layers underneath. Cutting depth is adjustable.

I Chamfering tool, size 2



Order numbers: chamfering tool 55154 / spare cutter 44129

This very simple to handle tool removes sharp edges at the cut-off edge of cable insulation to avoid possible damage to and to ease installation of slip-on accessories. It can be used for diameters over core insulation between 15 mm up

to 60 mm after peeling the outer sheath. Due to its specially formed blade a radius is produced at the cut-off edge. This reduces the force required to install non-size sensitive slip-on accessories enormously.

CABLE PREPARATION TOOLS

for accessories installation in medium voltage applications

I Tool case complete, size 1 (for cross-sections up to 500 mm²)

Order number:

Tool case complete 51426

I Tool case complete, size 2 (for cross-sections > 500 mm²)

Order number:

Tool case complete 55155



(Figure: Tool case complete, size 1, for cross-sections up to 500 mm²)

I Kit contents

Rigid case with foam pads, two-in-one cable sheath and cable insulation cutter, chamfering tool, devices (stop rings, silicone grease and Allen key for tooling adjustments).

DMV65

Torque amplifier with tool case

Application

The torque amplifier DMV65 is appropriate for a gentle removal of shear-off-head bolts in mechanical connectors using standard cordless screwdrivers. The tool enables an optimum clamping force using mechanical GPH® connectors with conductor cross-sections up to 630 mm². The DMV65 ensures outstanding installation quality for mechanical connectors and cable lugs up to Ø 52 mm.

Technical characteristics

- Triangle
- 1/2" Square inserting the socket wrench
- Rods length 80.5 mm
- Transmission ratio 1:24
- Max. engine torque 65 Nm
- Min. driving torque 3.5 Nm
- Weight 941 g



Kit contents

- Tool case with foam pads
- Outer hexagon tools SW10, 13, 14, 17, 19, 22, 24
- Inner hexagon tools SW5, 6, 8, 10
- Hexagon socket key SW5
- Instruction manual

Design

- Rods, assembled, length 80.5 mm
- Rod socket
- Inner tapped hole for Ø < 40 mm
- Outer tapped hole for Ø < 53 mm
- 1/2" Square with ball coupling
- Release hole
- Gearbox
- Triangle
- Hexagon socket key SW5

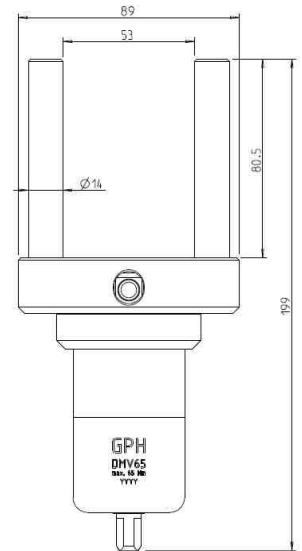

Material

- Operating parts and rods manufactured of high strength quality steel
- Engine body made of aluminum with anodised surface

Important notice

- The torque amplifier is not approved for live working installation.
- The tool is not allowed to be used in combination with an impact wrench.
- Consider the installation instruction of the respective mechanical connector or cable lug.

Ordering instructions

Type	Max. engine torque (Nm)	Package	Dimensions (mm)	Weight (g)
DREHMOMENTVERSTÄRKER DMV65 IM KOFFER	65	Tool case	375 x 240 x 120	2600

15-01-2019

DMV65

Torque amplifier, isolated, with tool case

Application

The isolated torque amplifier DMV65 is appropriate for a gentle removal of shear-off-head bolts in mechanical connectors using standard cordless screwdrivers. According to manufacturer self-test referring to EN 60900, the electrical isolation between installer and connector is given by the tool. Nevertheless, wearing of personal protective equipment (PPE) is mandatory.

Technical characteristics

- Triangle
- 1/2" Square inserting the socket wrench
- Rods length 81 mm
- Transmission ratio 1:24
- Max. engine torque 65 Nm
- Min. driving torque 3.5 Nm
- Weight 1380 g



Kit contents

- Tool case with foam pads
- Outer hexagon tools SW10, 13, 14, 17, 19, 22, 24
- Inner hexagon tools SW5, 6, 8, 10
- Hexagon socket key SW5
- Instruction manual

Design

- Installed rods, insulated, length 81 mm
- Cover plate
- Inner tapped hole for $\varnothing < 36$ mm
- Outer tapped hole for $\varnothing < 48$ mm
- Gearbox, insulated
- Triangle
- Hexagon socket key SW5

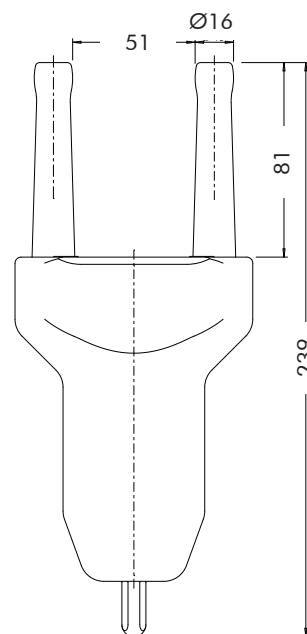

Material

- Operating parts and rods manufactured of high strength quality steel with plastic-covered surfaces (Polyamide PA)
- Engine body made of aluminum with plastic cover (Polyoxymethylene POM)

Important notice

- The contact with other connectors nearby must be avoided.
- The tool is not allowed to be used with an impact wrench.
- Consider the installation instruction of the respective mechanical connector or cable lug.

Ordering instructions

Type	Max. engine torque (Nm)	Package	Dimensions (mm)	Weight (g)
DREHMOMENTVERSTÄRKER POTENTIALGETRENNT DMV65	65	Tool case	375 x 240 x 120	3000

iDMV65

Torque amplifier iDMV65 with integrated drive and tool case

Application

The integrated torque amplifier DMV65 is the appropriate all-in-one tool for a gentle removal of shear-off-head bolts in mechanical connectors. It enables an optimum clamping force using mechanical GPH® connectors with conductor cross-sections up to 630 mm². For the comfortable handling during the installation, the power unit is integrated into the gearbox.

Technical characteristics

- 1/2" Square inserting the socket wrench
- Rods length 80.5 mm
- Max. engine torque 65 Nm
- Li-Ion battery (12V/2.0 Ah)
- Charging time approx. 30 min
- Weight 2100 g



Kit contents

- Tool case with foam pads
- Outer hexagon tools SW10, 13, 14, 17, 19, 22, 24
- Inner hexagon tools SW5, 6, 8, 10
- Hexagon socket key SW5
- Instruction manual

Design

- Integrated cordless screw driver
- Installed rods, length 80.5 mm
- Rod socket
- Inner tapped hole for $\varnothing < 40$ mm
- Outer tapped hole for $\varnothing < 53$ mm
- 1/2" Square with ball coupling and release function
- Release hole
- Gearbox
- Hexagon socket key SW5



Material

- Cordless quality screw driver with battery charger
- Operating parts and rods manufactured of high strength quality steel
- Engine body made of aluminum with anodised surface

Important notice

- The torque amplifier is not approved for live working installation.
- Consider the installation instruction of the respective mechanical connector or cable lug.

Ordering instructions

Type	Max. engine torque (Nm)	Package	Dimensions (mm)	Weight (g)
DREHMOMENTVERSTÄRKER MIT INTEGRIERTEM ANTRIEB iDMV65 IM KOFFER	65	Tool case	340 x 230 x 70	4200

CATALOGUE SELECTION

Here you can find all available catalogues of our GPH®, EUROMOLD® and Nexans products. You can order these catalogues directly by phone or download from our web page.

www.nexans-power-accessories.com

Nexans Power Accessories

- GPH® Connection technology and tools
- Heat-shrinkable joints and accessories up to 0.6/1 (1.2) kV
- Heat-shrinkable power accessories up to 20.8/36 (42) kV
- Cold-shrinkable joints
- EUROMOLD® Medium voltage equipment bushings
- EUROMOLD® Medium voltage terminations, cold-shrink and slip-on
- Medium voltage terminations, heat-shrink
- High voltage accessories up to 72.5 kV
- High voltage accessories up to 170 kV
- EUROMOLD® Separable connectors for interface A
- EUROMOLD® Separable connectors for interface B
- EUROMOLD® Separable connectors for interface C
- EUROMOLD® Separable connectors for interface D
- EUROMOLD® Separable connectors for interface E
- EUROMOLD® Separable connectors for interface F

CABLE DATA SHEET INQUIRY FORM

Nexans Power Accessories Germany GmbH

Ferdinand-Porsche-Straße 12
D-95028 Hof/Saale

Phone: +49(0)9281 / 8306 - 0
Fax: +49(0)9281 / 8306 - 480
E-Mail: info.power-accessories@nexans.com

Company:

Customer ID:

Address:

Phone:

Fax:

E-Mail:

Cable designation

Cable data

Single-core

Three-core

Other

Single-core flexible rubber insulated cable

Three-core flexible rubber insulated cable

Standard

Conductor material

Aluminum

Copper

cross-section

mm²

Conductor shape

Round stranded (compacted) conductor

Round solid conductor

Sector stranded conductor

Sector solid conductor

Flexible conductor

RM(V)

RE

SM

SE

RF

Other

System voltage

3.6/6 (7,2) kV

6/10 (12) kV

6.35/11 (12) kV

8.7/15 (17,5) kV

12/20 (24) kV

12.7/22 (24) kV

18/30 (36) kV

19/33 (36) kV

20.8/36 (42) kV

Other:.....

Cable type

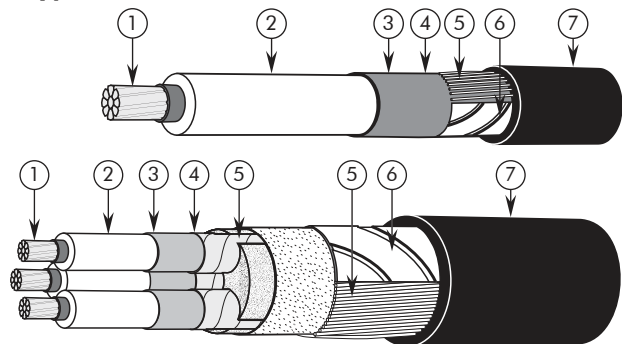

1. Ø conductor mm

2. Ø over core insulation mm

3. Ø over semi-conductive screen mm

4. Semi-conductive layer bonded graphite coated

5. Metal screen Al Cu wire screen

6. Armour type Yes No mm

XLPE

PVC

EPR

easy strip

tape screen

armour max. current A

cross-section

NOTES



Nexans Power Accessories Germany GmbH

Ferdinand-Porsche-Str. 12

95028 Hof/Saale

Tel.: +49 9281 8306-0

info.power-accessories@nexans.com

www.nexans-power-accessories.com



Find out more about Nexans Power Accessories.